

RECLAMATION

Managing Water in the West

Interim Report: Revegetation Strategies and Plant Materials Selection for Restoration of Xeric *Tamarix* Infestation Sites Following Fire

Cibola National Wildlife Refuge



**U.S. Department of the Interior
Bureau of Reclamation
Technical Service Center
Denver, Colorado**

March 2009

Acknowledgements

Our sincere thanks to Bill Seese, Mike Oldham, Joe Barnett, Dominic Barrett, and Frank Kribbs at Cibola National Wildlife Refuge for excellent, timely provision of equipment, site preparation, selected land treatments, and access to facilities and storage yards. Their help and ongoing maintenance of the studies were/are invaluable.

Special thanks is also extended to Juli Fahy and Roger Burnett for their diligent, hard work in the absence of family over a continuous 3+ week period in completing the installations, in concert with their great patience, work ethic, and positive attitude over hard days, demanding work, and complicated implementation.

Mycorrhizal inoculum and polyacrylamide polymer, in the form of biodegradable “teabags” for transplant materials and seed coating-grade, powdered mycorrhizal spore and polymer materials for seedings, were graciously provided in the interest of scientific study at no cost by Neil Anderson, President, Reforestation Technologies International, Salinas, California. Incorporation of a key component of this study, in light of design and results obtained, was made possible by this generous contribution.

Zeolite material was also provided at no cost by John Bokich, Vice President of Operations, St. Cloud Mining Company, Truth or Consequences, New Mexico. Research into zeolite column technology for the purpose of vegetative restoration continues to evolve with the generous support such as was provided for this study.

Finally, our thanks to Melissa, Jocelyn, Jay, Stan, Brett and Jordan of the Student Conservation Association (SCA) for their similarly great work ethic and assistance in completing the transplanting and perimeter fencing on-schedule.

Contents

| | |
|---|-----------|
| BACKGROUND | 1 |
| SALT CEDAR MANAGEMENT | 2 |
| INFORMATION NEEDS | 4 |
| DEMONSTRATION STUDIES | 5 |
| OBJECTIVE | 5 |
| METHODOLOGY | 6 |
| <i>Demonstration Study Sites</i> | 6 |
| <i>Demonstration Study Design and Statistical Analysis Overview</i> | 13 |
| <i>Data Analysis</i> | 13 |
| <i>Demonstration Study Treatments</i> | 14 |
| <i>Compliance Planning</i> | 27 |
| <i>Implementation</i> | 27 |
| RESULTS – 2008..... | 27 |
| <i>Post-treatment monitoring</i> | 27 |
| <i>Irrigation Duration</i> | 29 |
| <i>Treatment Results</i> | 30 |
| DISCUSSION | 38 |
| <i>Treatments</i> | 38 |
| <i>General</i> | 39 |
| SUMMARY AND CONCLUSIONS..... | 42 |
| FUTURE ACTIVITIES AND RESEARCH NEEDS..... | 43 |
| LITERATURE CITED | 45 |

Background

Fire Description

Adapted from Cibola Fire, Burned Area Rehabilitation Plan; Parametrix, Inc. 2006.

The Cibola Fire was ignited by a lightning-strike on July 17, 2006 on the Cibola National Wildlife Refuge, La Paz County, Arizona (Figure 1). The fire was controlled on July 22, after burning a total of 4,662 acres. The fire burned a mix of saltcedar (primarily *Tamarix ramosissima*) and native vegetation (honey mesquite, *Prosopis glandulosa*; screwbean mesquite, *P. pubescens*; arrowweed, *Pluchea sericea*; and quailbush, *Atriplex lentiformis*). Much of the area that burned was in saltcedar-dominated habitat. This species is fire-adapted, root-sprouts vigorously following burning, and if not treated will form dense stands of re-sprout material. Given these ecological traits, saltcedar typically will crowd out native riparian and wetland vegetation beneficial for native wildlife. The bare, disturbed soil present over most of the burned area also provides an opportunity for invasion by several classes of exotic and noxious invasive species.

Values immediately in danger include potential habitat for the federally-endangered Southwestern willow flycatcher (*Empidonax trailii extimus*), Yuma Clapper Rail (*Rallus longirostris yumanensis*), one Candidate Species, the yellow-billed cuckoo (*Coccyzus americanus*), and two captive reared endangered fish. The greatest post-fire threats to resources are:

- Increased cover and density of exotic species and noxious weeds within the burned area and in adjacent critical habitat for the willow flycatcher.
- Continued extreme fire hazard within burned area and to adjacent habitat resulting from rapid regeneration of exotic saltcedar re-growth (an Arizona designated Class C noxious weed).

The following Burned Area Rehabilitation (BAR) activities and treatments were recommended for the Cibola Fire site:

- Gather essential information required for rehabilitation planning on 1,840-acre priority area.
 - Perform Order 1 soil survey and soil salinity assessment
 - Obtain high resolution topographic survey (LIDAR)
 - Map groundwater depth and flow patterns.
- Root plow, rake, and pile and burn salt cedar in 1,840-acre priority area.
- Monitor saltcedar re-growth and invasive species establishment in the 1,840-acre priority area to guide subsequent rehabilitation treatments.
- Implement herbicide treatments to saltcedar re-growth and noxious weeds following mechanical saltcedar treatment in the 1840-acre priority area

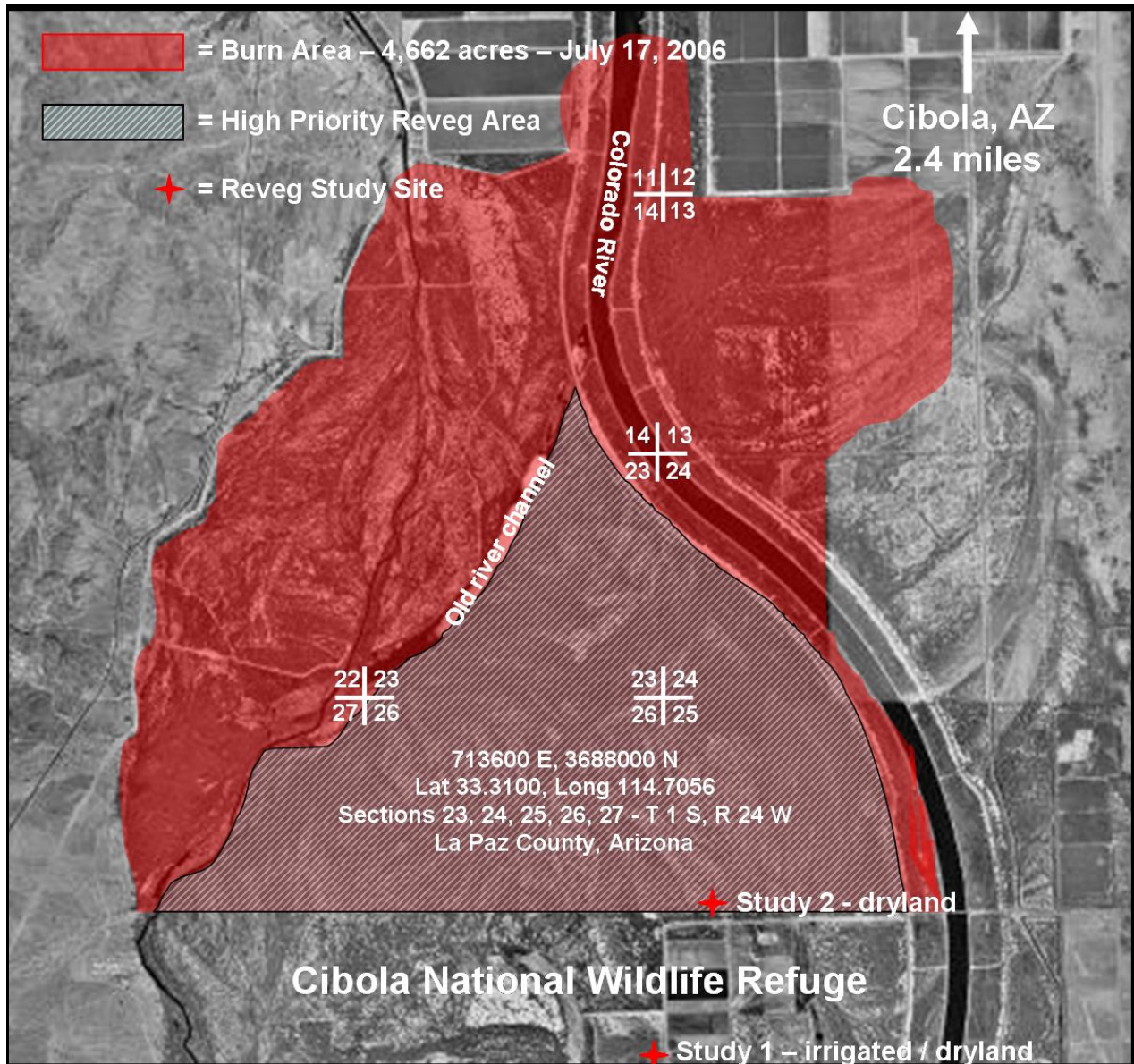

Figure 1. Cibola National Wildlife Refuge burn area, Cibola, Arizona. Burn occurred July 17-22, 2006, covering 4,662 acres (1,903 ha).

Saltcedar Management

Executive Order 13112 (Invasive Species) mandates that federal agencies control and monitor invasive species, provide restoration of native species and desirable habitat conditions in ecosystems that have been invaded, and conduct research to develop technologies to prevent introduction and provide environmentally sound control of invasive species. Land treatment and research are often driven by desirable control measure effectiveness, with only secondary emphasis on ability of sites to sufficiently recover vegetatively for site stabilization and habitat value enhancement (Lair and Wynn 2002, DeLoach et al. 2000, Anderson and Ohmart 1979).

On xeric, saline sites, recovery of desirable vegetation may be the most limiting factor for site enhancement (Anderson 1995).

Tamarix spp. (saltcedar) is a highly invasive exotic shrub that has invaded thousands of acres along many major river systems (Bureau of Reclamation 2000, McDaniel et al. 2000, Crawford et al. 1993). Throughout the western United States, saltcedar infestation has been documented to produce adverse environmental effects in riverine and lacustrine systems. These effects include increased wildfire potential resulting from high densities of fine, woody fuel materials; significant reduction in biodiversity, wildlife habitat, and riparian ecosystem function and structure; and significant reduction of surface and groundwater return flows (Zavaleta 2000a, b, California Exotic Plant Pest Council 1998, University of California 1996, Anderson 1995, Crawford et al. 1993). Saltcedar spreads by seed dispersal and vigorous sprouting from lateral roots and decumbent stems (i.e., prostrate stems with nodes in contact with the soil surface), competitively and rapidly displacing native stands of cottonwood (*Populus*), willow (*Salix*), and grasses that are more fire-resistant (Wiesenborn 1996, Lovich 1996, Anderson and Ohmart 1979, Warren and Turner 1975).

Saltcedar has been implicated in severe reduction of habitat value within the riparian corridors of major river systems (Anderson 1995, Crawford 1993, Anderson and Ohmart 1979). Saltcedar has been suggested as a possible cause of habitat reduction along the Canadian River system for many native fish and wildlife species, including the endangered Arkansas River Shiner (*Notropis girardi*) (Eberts 2000, M. Davin personal communication). One implication of this requirement is that additional water (via surface and groundwater return flow contributions) will be needed to support improved habitat for this fish. Landscape-scale management of saltcedar could positively address this need because of saltcedar's phreatophytic growth regime, high consumptive use (evapotranspiration) rate, high stand densities, and increasing infestation extent. Similarly, adverse impacts of saltcedar infestation on habitat of the southwestern willow flycatcher (*Empidonax extimus trailii*) have been well documented (DeLoach et al. 2000, Dudley et al. 2000, Zavaleta 2000a, b, Carpenter 1998, Anderson and Ohmart 1979).

Fire prevention and management in natural areas is exacerbated in dense saltcedar stands (Zavaleta 2000a, Wiesenborn 1996, Busch 1995, Scurlock 1995, Friedman and Waisel 1966). Saltcedar is a multi-stemmed invasive (exotic) shrub, sprouting basally from the root crown and lateral roots (Carpenter 1998, DiTomaso 1996). It can produce near continuous cover, ladder fuel structure and extremely high standing biomass of fine to medium, woody fuel material (Wiesenborn 1996, Busch 1995). In dense, monotypic stands, mean canopy height can exceed 12 meters, with canopy closure (aerial cover) often approaching 100% (Lair and Wynn, unpublished data), resulting in high potential for canopy fire carry. Saltcedar stands are often characterized by dense understory and soil surface litter layers comprised of additional fine fuels consisting primarily of annual grasses (e.g., Japanese brome [*Bromus japonicus*], cheatgrass (*Bromus tectorum*)), and saltcedar leaf litter (Lair and Eberts 2002).

Saltcedar biomass reduction resulting from fire requires site-specific evaluation for restoration potential. Stimulation of resprouting and increases in saltcedar density from remaining live root crowns and stems may occur. The increased proportion of young, active growth increases competition for moisture, nutrients and solar energy with planted vegetation. Use of prescribed fire for biomass reduction needs site-specific evaluation and stringent controls as a viable tool. Fire may yield an interaction of both positive and negative impacts. For example:

- Soil surface disturbance in the types and intensities needed for adequate soil surface manipulation (seedbed preparation) is still absent (Pinkney 1992, Szaro 1989).
- Rapid reduction of saltcedar canopy over large areas in the event of uncontrolled fire is undesirable because of habitat sensitivity on sites occupied by endangered species such as the southwestern willow flycatcher (Wiesenborn 1996, Busch 1995);

Information Needs

Critical knowledge gaps exist regarding restoration of saltcedar infestations, for which limited research or field experience exists, especially on xeric sites. Specifically, major information needs include strategies and techniques for vegetative recovery in a) xeric, mature, monotypic saltcedar stands with no (desirable) understory; and b) sites where potential is limited for natural or artificial recovery of willow and/or cottonwood species because of unavailability of supplemental water (via seasonal flooding, shallow water table, or irrigation). Best management practices are needed that integrate multiple management tools and are capable of addressing both localized (small scale) and landscape-scale, mesic and xeric saltcedar infestations. These practices should result in implementation of control and revegetation measures that provide a) rapid initial reduction of saltcedar; b) maintenance of control over extended time periods; and c) establishment of desirable vegetation that is ecologically (successionally) sustainable, competitive, resilient to further disturbance, and provides multiple habitat, site stability and forage benefits.

Reducing the time for establishment of desired levels of cover, diversity, production and habitat values is important (Lair and Wynn 2002, Anderson 1995, Pinkney 1992). Natural recovery of saltcedar infestation sites following control measures, especially in less dense stands, needs to be evaluated in light of the definition of "recovery" and an acceptable time frame for it to occur. Natural recovery scenarios (i.e., not artificially revegetated) often require 10 years or more for establishment of desirable, native vegetation, with the first 1-5 years typically dominated by ruderal weedy species. A prime objective should be to shorten or circumvent an extended ruderal and/or bare period by establishing diverse habitat characterized by predominance of early-, mid-, and late-seral *perennial* species. This also minimizes potential for capillary rise and salt accumulation at the soil surface following saltcedar reduction, and maintains lower wildfire hazard. Some sites may need initial establishment of earlier seral species in order to cope with and adapt to harsh environmental conditions until the site stabilizes (from the standpoints of organic matter recovery, energy flow and nutrient cycling). Other sites may facilitate later seral species and accelerated successional strategies.

Development and application of revegetation strategies also need to parallel (keep pace with) technological developments in saltcedar biological control, which holds great potential for long-term control of *Tamarix* on landscape scales. Valuable information can be derived from studies involving control of saltcedar by biological agents, fire or herbicide application, especially in terms of the effect of growth medium manipulation (physically, biologically, chemically) on moisture capture and retention, restoration of a functional microbial community, species adaptation, and other management inputs. Amount and density of standing biomass (live and dead) remaining after control, seedbed preparation strategies, and time frame to achieve levels of

control sufficient to favor vegetation establishment and site protection/stabilization are problematic in dense, mature saltcedar stands.

Effective techniques for seedbed preparation and seeding/transplanting in standing dead or defoliated material are needed that are more cost-effective, require smaller equipment with less energy expenditure, and cause less environmental disturbance than conventional methods (e.g., root plowing/raking). Presence of dense standing dead or defoliated saltcedar biomass poses limitations in relation to seeding techniques, seed interception in aerial applications, and shading impacts. After natural or prescribed fire treatment, undisturbed soil surfaces impacted by saltcedar leaf litter accumulation, salinity, hummocky micro-relief, nitrogen limitations, and possible livestock trampling compaction may also restrict potential for successful revegetation. Absence of arbuscular mycorrhizae specifically symbiotic to native revegetation species (especially grasses and shrubs), because of the long duration of saltcedar occupation in dense, mature stands, may also be a significant constraint.

Saltcedar reduction may yield an interaction of both positive and negative impacts resulting from biological, fire or herbicide application, requiring site-specific evaluation for restoration potential. Soil surface disturbance in the types and intensities needed for adequate soil surface manipulation (seedbed preparation) is absent following fire and most herbicide applications. Brief review to date of saltcedar revegetation literature, and communication with researchers and land managers experienced in saltcedar control and site restoration on xeric sites with dense, mature, monotypic infestations indicate that revegetation is difficult in the absence of soil surface manipulation (i.e. some form of seedbed preparation) (Lair and Wynn 2002, Pinkney 1992, Szaro 1989, Horton et al. 1960). Different methods of achieving desirable growth medium conditions need testing through varied techniques of seedbed preparation to enhance micro-environmental conditions in the root zone of planted species, including saltcedar leaf litter dispersal or incorporation, improved contact of seed with mineral soil, salinity reduction in surface soil layers, and mycorrhizal fungi inoculation.

Demonstration Studies

Objective

The objective of these studies was to determine the potential suitability of applied revegetation strategies, technologies, and selected plant materials for site restoration/revegetation on xeric saltcedar infestation sites that recently burned (July 2006) on the Cibola National Wildlife Refuge (U.S. Fish and Wildlife Service). Development and evaluation of revegetation and habitat enhancement techniques were conducted in historically dominant or monotypic, burned saltcedar stands where potential for natural recovery of desirable, diverse native vegetation following fire is limited or negligible. The studies emphasized: a) native species selection and adaptation; b) revegetation species response to mechanical techniques for saltcedar biomass reduction and seedbed preparation; c) augmentation of soil moisture regime with limited irrigation, polyacrylamide polymer, and zeolite columns; and d) augmentation of mycorrhizal association.

Methodology

Demonstration Study Sites

Location

The project area for these demonstration studies is located approximately 2.5 miles (4.0 kilometers) south of Cibola, Arizona (Figure 2). Land ownership within the project area is Cibola National Wildlife Refuge (U.S. Fish and Wildlife Service). The general project area is situated at an elevation of approximately 230 feet (70 m) in the Cibola Valley, situated between the Colorado River (new channel) and the old, abandoned channel (now Lake) to the west (site center = approximate Colorado River mile 93.6; latitude 33.3100° N; longitude 114.7056° W; UTM Zone 11, NAD 27, 713600 E, 3688000 N; Sections 23 -27, T. 1 S., R. 24 W.). The site is also located approximately 11.5 miles (18.5 kilometers) southeast of Palo Verde, California.

General Site Characteristics

The demonstration study sites were comprised of variable stands of mixed saltcedar (with honey mesquite [*Prosopis glandulosa*], screwbean mesquite [*P. pubescens*], arrowweed [*Pluchea sericea*], quailbush [*Atriplex lentiformis*], and rarely creosotebush [*Larrea tridentata*]) and monotypic saltcedar. Saltcedar composition, density and canopy (pre-fire) decreases from south to north (i.e., from less mixed to more mixed stands) across the burned area. The general demonstration study site is bisected by several low elevation earthen berms that are remnants of water conveyance banks and fence lines from historic (now abandoned) cropland farming activities. The burn area is also traversed by numerous swales, abandoned ditches, and historic river flow channels. The irrigated study site was comprised (based on canopy cover) of 95% quailbush, 4% honey mesquite, and 1% screwbean mesquite, plus a trace of understory forbs including alkali mallow (*Malvella leprosa*) and salt heliotrope (*Heliotropium curassivicum*). A cursory examination of vegetation throughout the burn area found relatively few plant species. Composition of the vegetation community on the burn area was estimated to consist of mostly (approximately 90%) saltcedar (based on canopy cover) with small to moderate sized patches of arrowweed (7%), interspersed mesquites (3%), and rarely creosote (<1%).

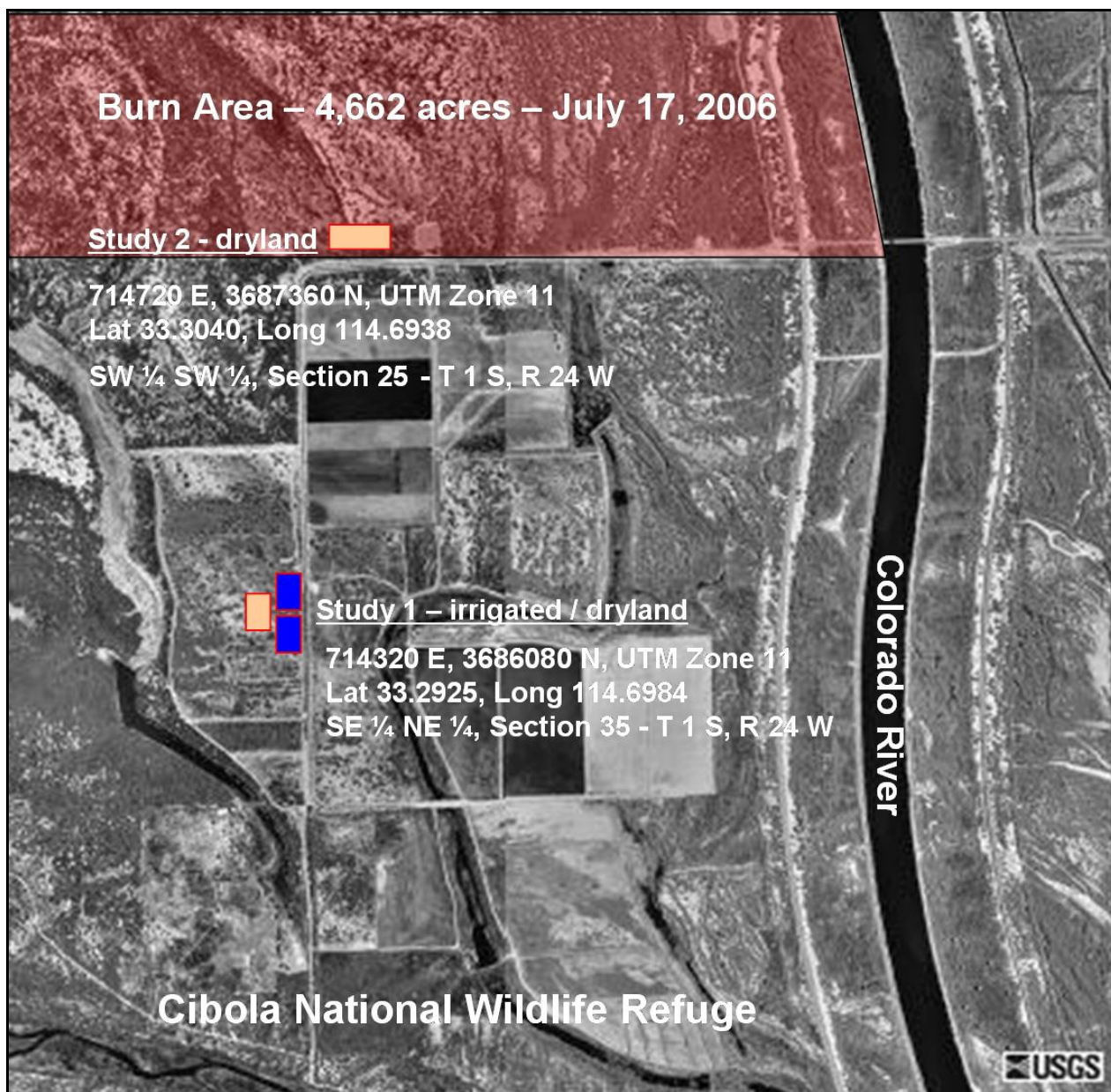

Figure 2. Saltcedar revegetation demonstration study site locations, Cibola National Wildlife Refuge burn restoration project, Cibola, Arizona. “Study 2” in figure is referred to as “Study 2A” throughout remainder of this document. Study 2B is not shown in this figure, and is located just north of Study 2A.

Climatic Regime

Mean annual precipitation for the general project area [derived from NOAA/WRCC long-term historic records at the Blythe, California (Site 040924; data period 1931-2005) and Yuma Proving Ground, Arizona (Site 029654; data period 1958-2005)] is approximately 3.83 in (9.73 cm) (WRCC 2007). Bimodal peaks in mean monthly precipitation occur in August and December, with all precipitation occurring as rainfall (48% received during the December through March growing season). Tabular summaries and precipitation frequencies and probabilities (Tables 1 and 2; Figure 1) were used to determine optimum dates for seeding and

planting initiation for the demonstration installations, and future landscape-scale implementation of the demonstration study findings in 2009 and beyond.

Table 1. Mean annual precipitation and temperature for the Blythe (CA)/Cibola (AZ) vicinity, as recorded at Blythe, California ((NOAA Station 040924). Percent of possible observations for period of record: maximum temperature - 97.3%; minimum temperature - 97.2%; precipitation - 97.4%. Period of Record: Jan 1, 1931 to December 31, 2005

| | Jan | Feb | Mar | Apr | May | Jun | Jul | Aug | Sep | Oct | Nov | Dec | Annual |
|--|------|------|------|------|------|-------|-------|-------|------|------|------|------|--------|
| Average Max. Temperature (°F) | 67.6 | 72.8 | 79.4 | 87.4 | 95.7 | 103.9 | 108.5 | 106.8 | 102 | 90.6 | 76.4 | 67.6 | 88.2 |
| Average Min. Temperature (°F) | 38.3 | 42.4 | 47 | 53.4 | 60.5 | 67.7 | 76.3 | 75.9 | 68.1 | 56 | 44.2 | 38.4 | 55.7 |
| Average Total Precipitation (in.) | 0.48 | 0.48 | 0.36 | 0.13 | 0.03 | 0.03 | 0.19 | 0.7 | 0.41 | 0.26 | 0.25 | 0.51 | 3.83 |

Western Regional Climate Center, wrc@dro.edu

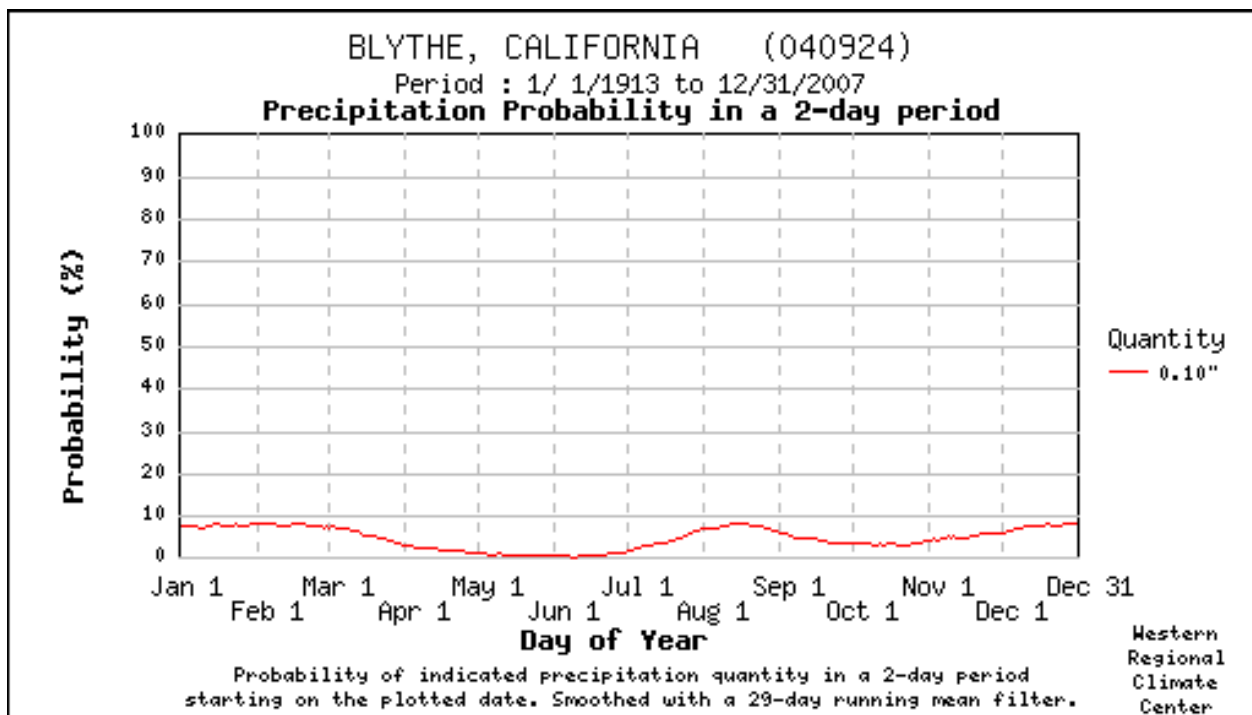

Figure 3. Probability of receiving 0.10 inch (0.25 cm) of precipitation in a 2-day period for the Blythe (CA)/Cibola (AZ) vicinity, as recorded at Blythe, California.

Table 2. Mean and extreme precipitation and probabilities for the Blythe (CA)/Cibola (AZ) vicinity, as recorded at Blythe, California. Period of Record: Jan 1, 1931 to December 31, 2005. Seasons are climatological, not calendar seasons (winter = Dec.–Feb., spring = Mar.–Apr., summer = Jun.–Aug., fall = Sep.–Nov.)

| | Mean in. | High in. | Year - | Low in. | Year - | 1 Day Max. in. Day | | ≥ 0.01 in. # Days | ≥ 0.1 in. # Days | ≥ 0.5 in. # Days | ≥ 1.00 in. # Days |
|------------------|-------------|-------------|-----------|------------|-----------|-----------------------|-----------|----------------------------|---------------------------|---------------------------|----------------------------|
| January | 0.48 | 3.56 | 1949 | 0 | 1931 | 2.1 | 12/1949 | 3 | 1 | 0 | 0 |
| February | 0.48 | 3.55 | 2005 | 0 | 1943 | 1.76 | 11/2005 | 2 | 1 | 0 | 0 |
| March | 0.36 | 2.50 | 1937 | 0 | 1931 | 2.5 | 16/1963 | 2 | 1 | 0 | 0 |
| April | 0.13 | 1.91 | 1965 | 0 | 1932 | 1.32 | 04/1965 | 1 | 0 | 0 | 0 |
| May | 0.03 | 0.63 | 1979 | 0 | 1931 | 0.6 | 25/1979 | 0 | 0 | 0 | 0 |
| June | 0.03 | 0.93 | 1972 | 0 | 1931 | 0.88 | 07/1972 | 0 | 0 | 0 | 0 |
| July | 0.19 | 1.59 | 1937 | 0 | 1932 | 1.22 | 07/2001 | 1 | 0 | 0 | 0 |
| August | 0.70 | 6.00 | 1951 | 0 | 1932 | 3.06 | 27/1951 | 2 | 1 | 0 | 0 |
| September | 0.41 | 5.72 | 1939 | 0 | 1934 | 2.56 | 26/1997 | 1 | 1 | 0 | 0 |
| October | 0.26 | 2.17 | 1972 | 0 | 1931 | 2.03 | 06/1972 | 1 | 1 | 0 | 0 |
| November | 0.25 | 1.85 | 1985 | 0 | 1932 | 1.27 | 01/1987 | 1 | 1 | 0 | 0 |
| December | 0.51 | 3.77 | 1984 | 0 | 1950 | 1.47 | 11/1941 | 2 | 1 | 0 | 0 |
| Annual | 3.83 | 8.71 | 1951 | 0.18 | 1956 | 3.06 | 8/27/1951 | 17 | 9 | 2 | 1 |
| Winter | 1.47 | 6.70 | 1993 | 0 | 1964 | 2.1 | 1/12/1949 | 7 | 4 | 1 | 0 |
| Spring | 0.52 | 3.16 | 1941 | 0 | 1932 | 2.5 | 3/16/1937 | 3 | 1 | 0 | 0 |
| Summer | 0.92 | 6.00 | 1951 | 0 | 1944 | 3.06 | 8/27/1951 | 3 | 2 | 1 | 0 |
| Fall | 0.93 | 6.43 | 1939 | 0 | 1935 | 2.56 | 9/26/1997 | 4 | 2 | 0 | 0 |

Western Regional Climate Center, wrc@dro.edu

Soils

Comprehensive pre-treatment (baseline) soil sampling was conducted on a systematic 660-foot (200 m) grid across the high-priority burn area during the summer of 2007, for which analyses were previously completed and submitted to the USFWS under separate reports by the Bureau of Reclamation (Figure 4). Using core sampling and electromagnetic techniques, demonstration study area soils were systematically sampled at various strata (roughly 1 foot [30 cm] increments up to 60 inches [152 cm] deep) for parameters of:

- Texture.
- Salinity (EC; surface and subsoil).
- Percent salt content.
- Reaction (pH).
- Moisture content/availability.



Figure 4. Sampling for baseline soil characteristics at the demonstration study sites, Cibola National Wildlife Refuge, Cibola, Arizona.

An EM38 electrical conductivity meter (Geonics Limited, Mississauga, Ontario, Canada) was also used to indirectly determine soil EC via electromagnetic conductance down to 36-inch (91 cm) soil depth, for correlation with, and quality control (independent confirmation) of core sample values. The EM_v is the ‘vertical’ reading, representing 0-36” depth range of detection; EM_h is the ‘horizontal’ reading, representing 0-12” depth range.

Soils of the general project area are primarily deep, well-drained clays and silt loams characteristic of the Indio soil series (USDA-NRCS Yuma – Wellton Area, Arizona Soil Survey, 1980). These soils are common to flood plain and alluvial sites (0-1% mean slopes) along this portion of the lower Colorado River, with frequent occurrence of fine to very fine sandy loam in surface and subsoil materials. Soils may be moderately-to-strongly saline, with depths to bedrock typically exceeding 60 inches (152 cm). These values appear to be moderately variable across the project area but are assumed to be relatively uniform within individual study sites (Table 3 and Figures 5 and 6).

Table 3. Average (AVG), standard deviation (STD) and range (minimum-maximum) values of soil parameters. Calculated from soil samples covering entire burn area (660-foot grid).

| Depth (in.) | pH | | ECe (mMHOS/cm) | | % Saturation | | % Salt | |
|----------------|-----------|---------|----------------|-----------|--------------|------------|-----------|----------|
| | AVG (STD) | Range | AVG (STD) | Range | AVG (STD) | Range | AVG (STD) | Range |
| 0 - 6 | 7.9 (0.4) | 6.8-8.7 | 69.7 (49.0) | 2.0-209.0 | 43.2 (8.5) | 19.0-67.9 | 1.9 (1.3) | 0.04-5.6 |
| 6 - 12 | 8.1 (0.3) | 7.4-8.7 | 29.4 (16.3) | 1.8-98.8 | 44.7 (10.7) | 26.6-87.8 | 0.9 (0.5) | 0.04-2.7 |
| > 12 | 8.3 (0.3) | 7.6-9.5 | 19.3 (10.0) | 2.2-45.5 | 45.4 (17.3) | 26.1-108.6 | 0.6 (0.4) | 0.04-1.7 |

Except for demonstration study 1, the sites were representative subunits of the larger sampling effort. Site-specific samples taken at Study Sites 1 and 3 (irrigated demonstration and non-irrigated zeolite column demonstration, respectively) indicated silty-clay to clay-textured surface horizons (top 25 inches [64 cm]) with high salinity levels (16.9 – 33.1 dS m⁻¹).

| CIBOLA NWR - Soil Survey of the 2006 Burn Area | | | | | | | | | | | | | | | | | | | | | | | | | | | | | | | | | | | | | | | | | | | | | | | | | | | | | | | | | | | |
|--|---------------------|-----------------|-----------------|--------------------------------|--------------------------|-----------------------|-------------------------------|----------|----------|--------|---------------------------------|--|--------------------|-----------------|-----------------|-----------------|-----------------|------------------------------|--|-----|-----|-----|-----|------------------------|--|-----|-----|-----|-----|-----------|--|-----|-----|-----|-----|-------------------------|--|-----|-----|-----|-----|---------------------|--|-----|-----|-----|-----|--|--|-----|-----|-----|-----|--|--|-----|-------|--|--|
| Boring# | Ken's Irrig. Site | Sampler | Brummer | Date | 4/27/07 | | | | | | | | | | | | | | | | | | | | | | | | | | | | | | | | | | | | | | | | | | | | | | | | | | | | | | |
| Location(UTM/NAD83) | 11 S 714359 3686332 | | | Uncertainty | 9' | Offset | Center of Irrig. Field Site | | | | | | | | | | | | | | | | | | | | | | | | | | | | | | | | | | | | | | | | | | | | | | | | | | | | |
| Topography | nearly level | | | Vegetation & Condition | Quailbush | | | | | | | | | | | | | | | | | | | | | | | | | | | | | | | | | | | | | | | | | | | | | | | | | | | | | | |
| Parent Material | | | | Depth to Watertable | 66" after 15 minutes | | | | | | | | | | | | | | | | | | | | | | | | | | | | | | | | | | | | | | | | | | | | | | | | | | | | | | |
| Plow Layer Texture(0-10") | Heavy | | | Textural Family(10-40") | NRCS Soil Type: Imperial | | | | | | | | | | | | | | | | | | | | | | | | | | | | | | | | | | | | | | | | | | | | | | | | | | | | | | |
| Avg EM Measurements; | EM _v | 287 | EM _H | 266 | Soil Temperature(0-2") | 22.3 °C (12") 23.1 °C | | | | | | | | | | | | | | | | | | | | | | | | | | | | | | | | | | | | | | | | | | | | | | | | | | | | | |
| Estimated ECe (12-60") | 22.6 dS/m | | | Thickness of Ash Layer(inches) | none | | | | | | | | | | | | | | | | | | | | | | | | | | | | | | | | | | | | | | | | | | | | | | | | | | | | | | |
| PROFILE DESCRIPTION AND LABORATORY DATA | | | | | | | | | | | | | | | | | | | | | | | | | | | | | | | | | | | | | | | | | | | | | | | | | | | | | | | | | | | |
| Sample Number | Depth (inches) | Field Texture | Color | % Clay | % Sand | Reaction to HCL | Moisture Content ¹ | pH Paste | ECe dS/m | Sat. % | Notes: Sat.Paste Color, 10YR | | | | | | | | | | | | | | | | | | | | | | | | | | | | | | | | | | | | | | | | | | | | | | | | |
| | 0-12 | SiCL | Brn-Gry | 36 | 15 | ++ | Dry | 7.6 | 33.10 | 58.2 | 4.3;Very dry, hard to dig | | | | | | | | | | | | | | | | | | | | | | | | | | | | | | | | | | | | | | | | | | | | | | | | |
| | 12-25 | C | Dk.Brn | 45 | 20 | ++ | Moist | 8.1 | 16.93 | 105.6 | 5.4;Few Salts | | | | | | | | | | | | | | | | | | | | | | | | | | | | | | | | | | | | | | | | | | | | | | | | |
| | 25-42 | SiL | Dk.Brn | 21 | 20 | ++ | VM | 8.0 | 12.44 | 68.4 | 4.3;Few Mottles, some SiCL | | | | | | | | | | | | | | | | | | | | | | | | | | | | | | | | | | | | | | | | | | | | | | | | |
| | 42-59 | SiC | Dk.Brn | 40 | 15 | ++ | Wet | 8.2 | 3.73 | 79.2 | 4.4;Few Mottles, Fine SiC/SiC | | | | | | | | | | | | | | | | | | | | | | | | | | | | | | | | | | | | | | | | | | | | | | | | |
| | 59-69 | SiL | Dk.Brn | 24 | 15 | ++ | W-Sat | 8.2 | 3.18 | 52.3 | 4.3;Common Mottles | | | | | | | | | | | | | | | | | | | | | | | | | | | | | | | | | | | | | | | | | | | | | | | | |
| | | | | | | | | | | | | | | | | | | | | | | | | | | | | | | | | | | | | | | | | | | | | | | | | | | | | | | | | | | | |
| ¹ D-Dry (below wilting point); SM-Slightly Moist (wilting point to readily available moisture); M-Moist (readily available moisture to field capacity); VM-Very Moist (field capacity); W-Wet (above field capacity); S-Saturated (below watertable) | | | | | | | | | | | | | | | | | | | | | | | | | | | | | | | | | | | | | | | | | | | | | | | | | | | | | | | | | | | |
| Site Remarks: <table border="1" style="width:100%; border-collapse: collapse;"> <thead> <tr> <th style="width:40%;"></th> <th style="width:10%;">EM38 Measurements:</th> <th style="width:10%;">EM_v</th> <th style="width:10%;">EM_H</th> <th style="width:10%;">EM_v</th> <th style="width:10%;">EM_H</th> </tr> </thead> <tbody> <tr> <td>Free water in bottom of hole</td> <td></td> <td>201</td> <td>148</td> <td>346</td> <td>318</td> </tr> <tr> <td>Sat.Paste Color, 10YR:</td> <td></td> <td>252</td> <td>195</td> <td>384</td> <td>386</td> </tr> <tr> <td> 4.3 Brown</td> <td></td> <td>391</td> <td>363</td> <td>226</td> <td>266</td> </tr> <tr> <td> 4.4 Dk. Yellowish Brown</td> <td></td> <td>395</td> <td>394</td> <td>227</td> <td>262</td> </tr> <tr> <td> 5.4 Yellowish Brown</td> <td></td> <td>158</td> <td>156</td> <td>347</td> <td>290</td> </tr> <tr> <td></td> <td></td> <td>181</td> <td>179</td> <td>314</td> <td>258</td> </tr> <tr> <td></td> <td></td> <td>308</td> <td>246 *</td> <td></td> <td></td> </tr> </tbody> </table> | | | | | | | | | | | | | EM38 Measurements: | EM _v | EM _H | EM _v | EM _H | Free water in bottom of hole | | 201 | 148 | 346 | 318 | Sat.Paste Color, 10YR: | | 252 | 195 | 384 | 386 | 4.3 Brown | | 391 | 363 | 226 | 266 | 4.4 Dk. Yellowish Brown | | 395 | 394 | 227 | 262 | 5.4 Yellowish Brown | | 158 | 156 | 347 | 290 | | | 181 | 179 | 314 | 258 | | | 308 | 246 * | | |
| | EM38 Measurements: | EM _v | EM _H | EM _v | EM _H | | | | | | | | | | | | | | | | | | | | | | | | | | | | | | | | | | | | | | | | | | | | | | | | | | | | | | |
| Free water in bottom of hole | | 201 | 148 | 346 | 318 | | | | | | | | | | | | | | | | | | | | | | | | | | | | | | | | | | | | | | | | | | | | | | | | | | | | | | |
| Sat.Paste Color, 10YR: | | 252 | 195 | 384 | 386 | | | | | | | | | | | | | | | | | | | | | | | | | | | | | | | | | | | | | | | | | | | | | | | | | | | | | | |
| 4.3 Brown | | 391 | 363 | 226 | 266 | | | | | | | | | | | | | | | | | | | | | | | | | | | | | | | | | | | | | | | | | | | | | | | | | | | | | | |
| 4.4 Dk. Yellowish Brown | | 395 | 394 | 227 | 262 | | | | | | | | | | | | | | | | | | | | | | | | | | | | | | | | | | | | | | | | | | | | | | | | | | | | | | |
| 5.4 Yellowish Brown | | 158 | 156 | 347 | 290 | | | | | | | | | | | | | | | | | | | | | | | | | | | | | | | | | | | | | | | | | | | | | | | | | | | | | | |
| | | 181 | 179 | 314 | 258 | | | | | | | | | | | | | | | | | | | | | | | | | | | | | | | | | | | | | | | | | | | | | | | | | | | | | | |
| | | 308 | 246 * | | | | | | | | | | | | | | | | | | | | | | | | | | | | | | | | | | | | | | | | | | | | | | | | | | | | | | | | |

Figure 5. Soil characteristics of Demonstration Studies 1 and 3 at Cibola National Wildlife Refuge, Cibola, Arizona.

Site-specific samples taken adjacent to Demonstration Study Sites 2A and 2B (root-plowed and undisturbed burn sites, respectively) indicated more variable horizonation of textures, ranging from sand through loamy fine sand and fine sandy loam to loam, through 40 inches (102 cm) depth. As with Demonstration Study 1, extremely high salinity levels (15.5 – 53.1 dS m⁻¹) were detected in the surface 25 inches (64 cm). Characteristics of the top 40 inches (102 cm) of soil at Demonstration Study Sites 2A and 2B are summarized in Figure 6.

| CIBOLA NWR - Soil Survey of the 2006 Burn Area | | | | | | | | | | | | |
|---|---------------------|-------------------------|--------------------------------|--|-------------------|--|-------------------------------|-----------------------|-----------------------|--|------------------------------|--|
| Boring# | 53 | Sampler | Brummer/Johnson | Date | 4/5/07 | | | | | | | |
| Location(UTM/NAD83) | 11 S 715678 3687699 | Uncertainty | | Offset | 4' NE of Grid Pt. | | | | | | | |
| Topography | Nearly Level | Vegetation & Conditon | Burned Salt Cedar | | | | | | | | | |
| Parent Material | Meander Scroll | Depth to Watertable | | | | | | | | | | |
| Plow Layer Texture(0-10") | Light | Textural Family(10-40") | sandy | NRCS Soil Type | Ripley | | | | | | | |
| Avg EM Measurements; | EM _v 23 | EM _H 13 | Soil Temperature(0-2") | 37.0 °C (12") 25.6 °C | | | | | | | | |
| Estimated ECe (12-60") | 6.1 | dS/m | Thickness of Ash Layer(inches) | 0 | | | | | | | | |
| PROFILE DESCRIPTION AND LABORATORY DATA | | | | | | | | | | | | |
| Sample Number | Depth (inches) | Field Texture | Color | % Clay | % Sand | Reaction to HCL | Moisture Content ¹ | pH Paste | ECe dS/m | Sat. % | Notes: 10YR Sat.Paste Colors | |
| 53 | 0-6 | FSL | Pale Brn | 11 | 65 | ++ | D | 7.8 | 53.10 | 55.4 | 4.3 Brn; Soft & Loose | |
| 53 | 6-12 | L | Brn | 19 | 35 | +++ | D | 8.0 | 15.50 | 42.0 | 4.3 Brn; V.Hard, cloddy | |
| 53 | 12-24 | LFS | Pale Brn | 5 | 85 | ++ | SM | 8.5 | 5.15 | 33.1 | 4.4 DkYelBrn; S.G. & Loose | |
| 53 | 24-36 | S | Pale Brn | 3 | 92 | ++ | M | 8.5 | 5.76 | 28.9 | 4.4; S.G. & Loose | |
| NS | 36-40 | S | Pale Brn | 2 | 93 | ++ | M | | | | S.G. & Loose | |
| | | | | | | | | | | | | |
| | | | | | | | | | | | | |
| ¹ D-Dry (below wilting point); SM-Slightly Moist (wilting point to readily available moisture); M-Moist (readily available moisture to field capacity); VM-Very Moist (field capacity); W-Wet (above field capacity); S-Saturated (below watertable) | | | | | | | | | | | | |
| Site Remarks: | | | | | | | | | | | | |
| | | | | EM38 Measurements: | | | | EM_v | EM_H | EM_v EM_H | | |
| Young Salt Cedar; 30% resprout | | | | | | | | 25 | 15 | 26 13 | | |
| Site Visit 3/2/08 | | | | EM_v EM_H | | EM_v EM_H | | 19 | 10 | 24 12 | | |
| 19.8 °C at 12" | | | | 22 16 | | 20 13 | | 22 | 12 | 24 16 | | |
| Ave.EMv | | | | 22 | | 20 12 | | 31 | 17 | 20 11 | | |
| Ave.EMh | | | | 16 | | 20 12 | | 25 | 19 | 20 9 | | |
| Ece;0-6" | | | | 23.2 mS/cm | | 18 12 | | 18 | 12 | 24 14 *Site | | |
| Ece;6-12" | | | | 14.8 mS/cm | | 22 26 | | 20 | 16 | 22 14 | | |
| | | | | 22 14 | | 21 17 | | | | | | |

Figure 6. Soil characteristics of Demonstration Studies 2A and 2B, at Cibola National Wildlife Refuge, Cibola, Arizona.

Groundwater

Two-inch (5 cm) diameter, slotted, PVC-encased monitoring wells were installed to a minimum depth of at least 2 feet (0.6 m) below the upper fringe of the saturated zone for demonstration studies 1 and 3 (grouped) and studies 2A/2B (grouped) simultaneous with treatment applications, for monitoring groundwater depth and quality (via use of Troll 9000™, HydroLab™, or similar testing probe). The latter studies relied upon a nearby well (SE corner of Study 2a) installed as part of the larger burn monitoring well installations. Groundwater depth and quality measurements are to be conducted by the Hydrology Section staff of the Bureau of Reclamation (Denver TSC) and USFWS. These data will be used to correlate groundwater depth (and potentially water quality) with study treatments and results.

Planned groundwater measurement variables included:

- Ground water depth (baseline, pre-treatment and quarterly, post-treatment)
- Conductivity
- pH
- Alkalinity

Vegetation

Pre-treatment baseline inventories for vegetation (random transects, using line intercept, line point, and quadrat sampling) were planned for completion in the fall of 2007, immediately prior to treatment and related disturbance. All baseline data were to be compiled and structured for use in statistical comparisons to post-treatment results for soil and water data, and vegetative response to treatment, including:

- Species frequency, density and cover – existing species (pre-study).
- Species frequency and percent stand relative to seeding or planting rate.
- Basal and canopy cover, seeded and non-seeded.
- Vigor Index (function of culm and leaf height, seedhead production, and biomass).
- Bare ground and litter.

Reduced availability of funding, and diversion of the larger implementation phase over the full “island unit” to the consultant firms Parametrix and River Partners, however, precluded inclusion of this component within the research effort. A general description of the study sites has been provided earlier in this document (general site characteristics).

Demonstration Study Design and Statistical Analysis Overview

Demonstration studies incorporated replicated (3 or 4 blocks), split-split-plot factorial designs suitable for ANOVA and multivariate analyses, while still accommodating simple demonstration purposes. The designs incorporated evaluation of important response variables simultaneously within the same spatial and temporal context under a common error term. Univariate analysis was used in 2008 (first growing season after planting) to evaluate individual species responses in terms of survival alone. In future monitoring years (2009-10), univariate and multivariate techniques (e.g. discriminant analysis, canonical correlation, multiple linear regression) will be used to assess treatment responses using combinations of climate, soil, applied treatment, and multiple response (measured) variables. The studies incorporated control plots to reflect natural revegetation potential in the absence of treatment at all plot levels and within all replicates. Details of the study plan, experimental designs, and planned statistical analyses were previously provided to oversight team members (USFWS, BOR, Ducks Unlimited) at the Nov. 28-29, 2007 technical review meeting at the refuge.

Data Analysis

Statistical analysis procedures were applied to the data to test for significance of dependent variable (plant count) responses to treatment for single species. The analyses were conducted in accordance with procedures described in Gomez and Gomez (1984) and Steel and Torrie (1980). The BMDP statistical software package (BMDP Statistical Software, Inc., Los Angeles, Calif.; Dixon 1992) was used to perform all statistical analyses.

Analysis of variance (ANOVA) procedures were used since they are reasonably robust in relation to data non-normality and to moderate violations of the assumption of homogeneity of variance. This robustness is maintained when the shapes of data distributions are similar, samples are obtained randomly, sample sizes are equal, and mean separations are evaluated at confidence levels of 95% or greater (Manly 1994, Bonham 1992, Dixon 1992, Steel and Torrie 1980). The model used for ANOVA for all species is a mixed-effects model, incorporating both fixed effects (irrigation duration, polymer augmentation, replication) and random effects

(interactions of fixed effects, plus effects of covariates) (Steel and Torrie 1980). Non-parametric ANOVA tests were not used because: a) rapid loss of efficiency in determining true mean differences occurs for larger sample sizes ($n > 10$); b) most non-parametric procedures require matched-pair sampling and/or completely randomized or randomized complete block designs; and c) non-parametric procedures do not adjust for effects of covariates (Dixon 1992, Steel and Torrie 1980).

Data normality was evaluated for both raw and transformed data, using square root and arcsine square root transformations. None of these transformations resulted in statistical improvement in tests for data normality or homogeneity of variance for the dependent variable across all species. For simple plant count or percent cover data where many of the non-zero values occur in the range of 30-70, data transformation generally provides no improvement in achieving data normality (Steel and Torrie 1980). As a result of these findings, data were analyzed without transformation.

Three-way (4 x 3 x 4) factorial analysis of variance (ANOVA; BMDP-2V) was used to evaluate effects of irrigation duration, polymer augmentation, and replications, including analysis of covariates and interactions between treatments. Duncan's Multiple Range Test and Fisher's Least Significant Difference (LSD) test ($P=0.05$) were used to evaluate pairwise comparisons of differences between treatment means. In light of sample size and data variability for 2008 data sets, Fisher's Protected LSD (Steel and Torrie 1980) was ultimately used for mean separations in order to make the test more conservative. Simple-effect breakdowns for two-way interactions were provided if they were statistically significant ($P=0.05$), also using Fisher's Protected LSD procedure (1).

$$LSD = t_{\alpha} \sqrt{EMS (1/n_1 + 1/n_2)} \quad (1)$$

where: t_{α} = Student's t-value for sample size (degrees of freedom) and desired statistical power (probability; α).

EMS = error mean square from the ANOVA.

n_1 = sample size for the first group of the mean comparison.

n_2 = sample size for the second group of the mean comparison.

Demonstration Study Treatments

Study 1 - Irrigated (3 replications)

1st Level, Main plot: Irrigation Regime

- Full - long-duration (growing season)
- Partial - supplemental, short-duration (1-2 months)
- None - no irrigation (control)

2nd Level, Sub-Plot: Seeding/Planting Method

- Broadcast seeding with cultipacker
- Standard range drilled
- Transplants
- None (control; "natural" recovery)

3rd Level, Sub-Sub-Plot: Polyacrylamide Polymer Augmentation

- Polymer added
- No Polymer (control)

Demonstration Study 1 emphasized evaluation of revegetation species response to: a) no irrigation, limited (early, supplemental) irrigation, and full (season-long) irrigation; b) seeding/planting techniques that incorporate varying levels of seedbed preparation and depth of propagule placement; and c) use of polyacrylamide polymer for enhancement of soil moisture retention and duration within the initial root development zone.

The dimensions of each sub-plot is 25 feet (7.6 m) long by 6 feet (1.8 m) wide, accommodating 4 seed drill rows for the rangeland and deep-furrow plot drills. Treatments and related disturbance in Demonstration Studies 1 (including Study 3, which is nested within Study 1) impacted approximately 5.6 acres (2.3 ha) (Figure 7). This acreage is inclusive of buffer/access lanes that were established and subject to maintenance mechanically by mowing or disking between individual plots, between replications, and surrounding each entire study. Removal of existing honey and screwbean mesquite, and soil disturbance related to plot layout was avoided where possible outside of the study perimeters.

As a result of time and staff constraints, and the fact that soils on Study 1 (irrigated) still retained too much moisture to be suitable for the deep-furrow drilling, this treatment was omitted from the final layout (plots labeled “not seeded” on the attached plot diagram, Figure 7). This omission was considered of negligible impact to the purpose and outcome of Study 1, since this treatment’s value under an irrigated scenario is diminished in comparison to dryland applications. This treatment under the non-irrigated portion of Study 1 was replaced by zeolite column treatments, using six species of containerized transplant materials (described later in this document).

Study 2 - Non-Irrigated

1st Level, Main plot: Seedbed Preparation

- Root-plowed, root-raked, rough-leveled (**Study 2A**)
- No seedbed preparation (control) (**Study 2B**)

2nd Level, Sub-Plot: Seeding/Planting Method

- Broadcast seeding followed by cultipackers treatment
- Broadcast seeded followed by imprinter treatment
- Standard range drilled
- Deep-furrow drilled
- None (control; “natural” recovery)

3rd Level, Sub-Sub-Plot: Polyacrylamide Polymer Augmentation

- Polymer added
- No Polymer (control)

Demonstration Studies 2A and 2B targeted the evaluation of species adaptation to a) type and intensity of seedbed preparation/saltcedar biomass removal; b) seeding techniques (no transplants); and c) polyacrylamide polymer augmentation.

Similar to Study 1, because of time constraints necessitating an economization and prioritization of planned treatments, the deep-furrow drilling and standard range drilling treatments were omitted from Study 2B (burned area only; Figure 9). This treatment has more limited applicability to the undisturbed burn area because of physical interference to the treatment from post-burn standing dead and downed woody debris, and remnant live woody biomass (stems and roots). On undisturbed burn areas, broadcast seeding (ground-based or aerial applications) followed by the applied cultipacker or imprinter seedbed modification treatments, are considered the primary options available for this landscape scenario. The deep-furrow drilling treatment was conducted on the root-plowed Study 2A (Figure 8), since the woody debris constraint was negated by the root-plowing. The standard range drilling treatment was omitted from Study 2A because of time constraints (plots labeled “not seeded” on the attached plot diagram, Figure 8). As a result, deep-furrow drilling and the broadcast seeding methods were given priority over standard range drilling, given the time constraint and *relative* ecological value to restoration efforts in these surface-treatment scenarios.

The dimensions of each sub-plot is 25 feet (7.6 m) long by 6 feet (1.8 m) wide, accommodating 4 seed drill rows for the rangeland and deep-furrow plot drills. Treatments and related disturbance in Demonstration Studies 2A and 2B impacted approximately 6.0 acres (2.4 ha) (Figures 8, 9). Similarly to Demonstration Study 1, this acreage is inclusive of buffer/access lanes between individual plots, between replications, and surrounding each entire study. Removal of existing honey and screwbean mesquite, and soil disturbance related to plot layout was avoided where possible outside of the study perimeters.

Study 3 – Zeolite Columns

Zeolite is a substance similar to powdered vermiculite that exhibits excellent hydraulic conductivity/transport properties via capillary movement when condensed and saturated at one edge. Zeolites (clinoptilolites) are inert crystalline substances of volcanic origin that have been used as animal feed supplements, soil amendments to retain moisture, to enhance plant nutrients in root zones, and as water filtration media. It has been used most extensively as a soil amendment because of its ability to repeatedly hydrate and dehydrate, to adsorb nitrogen in the form of ammonium and then release it upon demand by a plant root system, and its durability, allowing it to retain these characteristics over several years. Columns of zeolite created from back-filling augered holes in areas where water tables are shallow can provide zones (“wetter circles”) of sub-irrigation moisture, wicked from the capillary fringe (i.e., vadose zone) to the rooting-zone of plants at the soil surface.

Zeolite column plots (as replacement for the deep-furrow drilled plots, Study 1, non-irrigated portion only) will be tested for utility in establishing “islands” of native vegetation (primarily from transplanted materials; potentially from seeded materials) in dryland (i.e., non-surface irrigated) situations. Upon establishment, these “islands” can then be used for seed dispersal and seedling recruitment across landscape-scale implementation areas, particularly under highly arid and saline conditions, and also to potentially serve as nurseries of selected species for subsequent seed harvest and/or transplanting at remote sites.

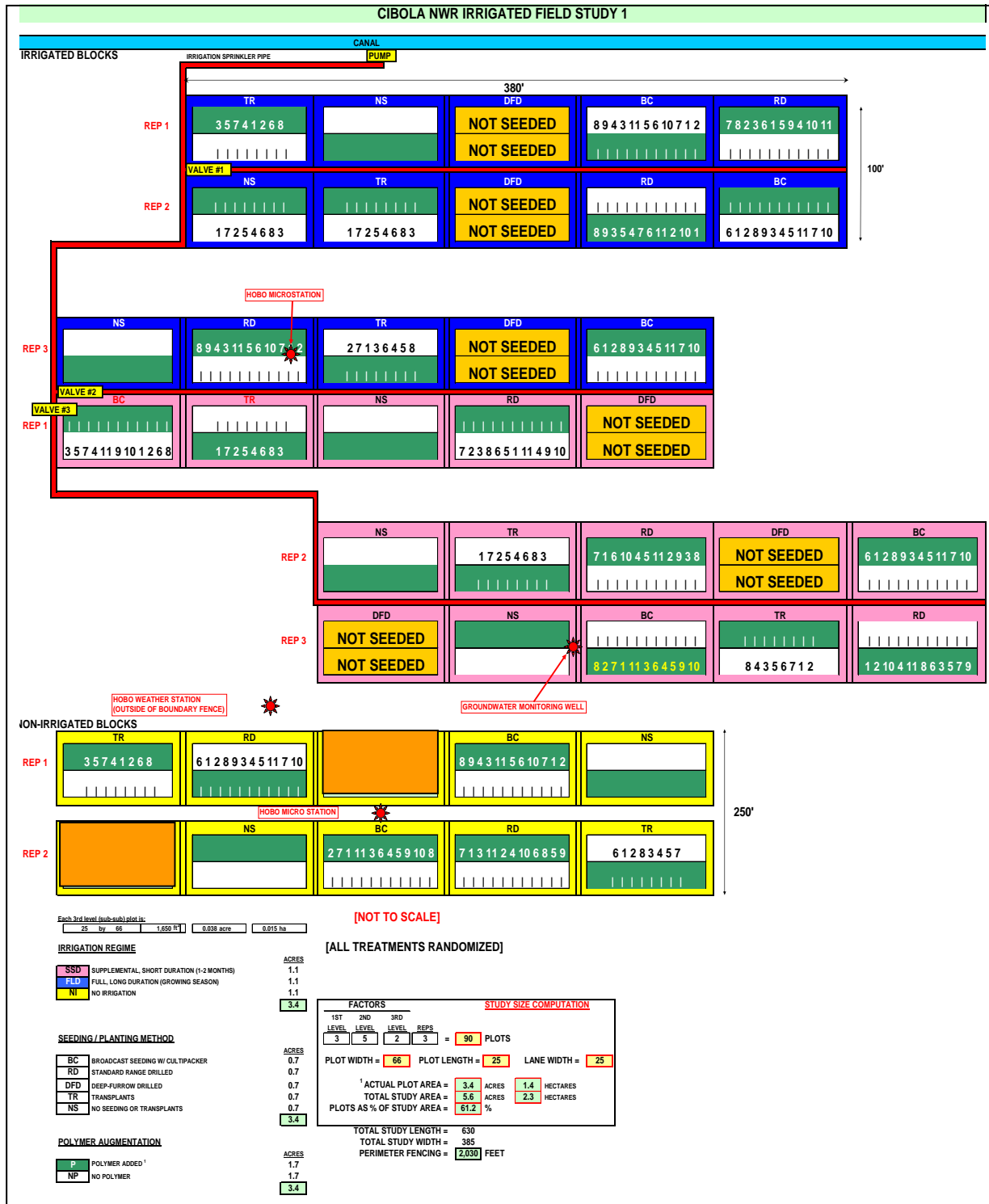

Figure 7. General layout of Demonstration Study 1 – Irrigated, Cibola National Wildlife Refuge, Cibola, Arizona. Demonstration Study 3 (brown highlight) was installed at a later date, and nested within the non-irrigated (yellow highlight) section of Demonstration Study 1.

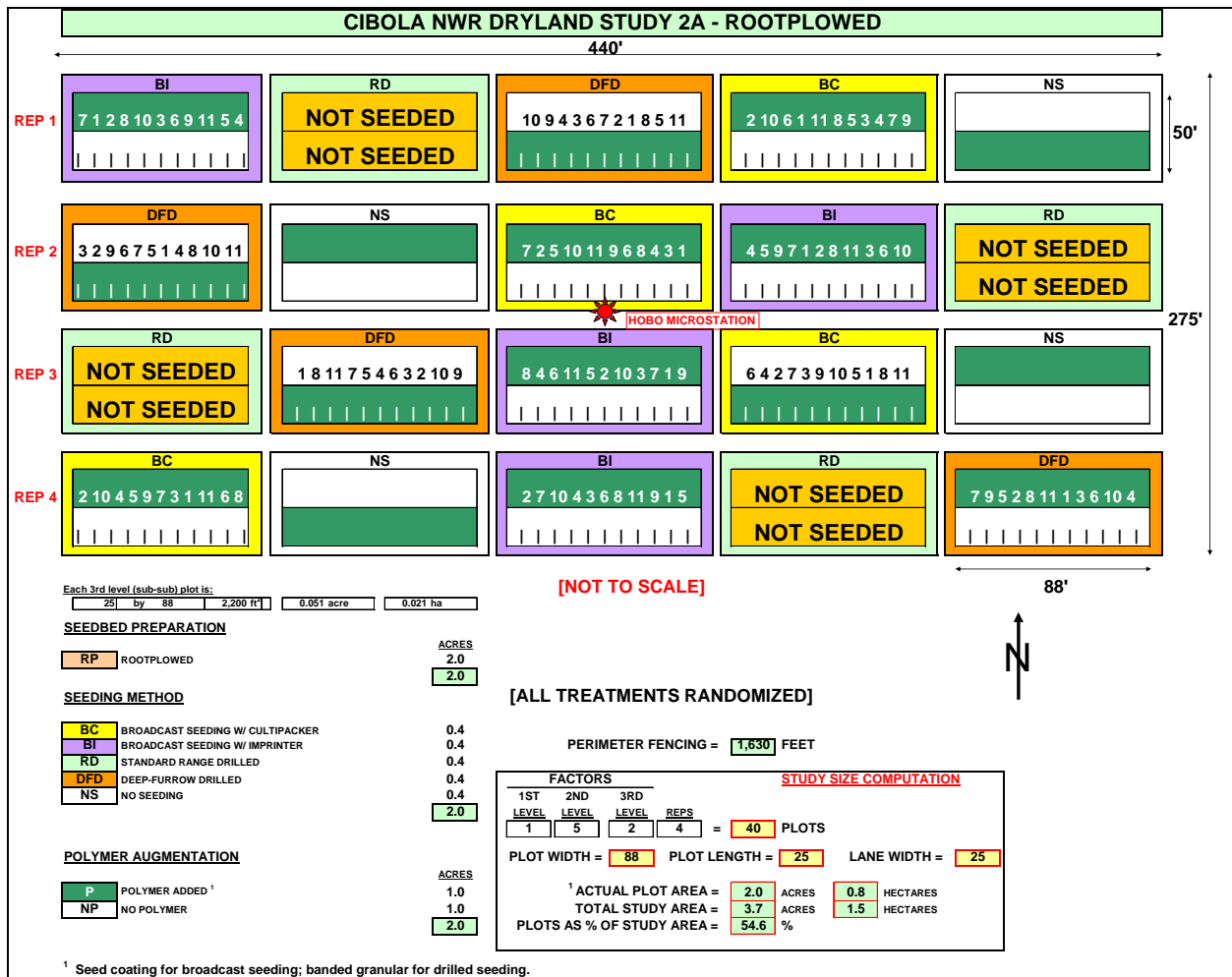

Figure 8. General layout of Demonstration Study 2A – Non-Irrigated, Cibola National Wildlife Refuge, Cibola, Arizona.

Zeolite material was obtained from St. Cloud mining company (Truth or Consequences, NM). Columns were installed in two of the plots within the non-irrigation section of Demonstration Study 1 (Figures 7). The columns were 4 inches (10 cm) in diameter and excavated using a hydraulic, truck-mounted auger down to 80 inches (200 cm) in depth (Figure 10). Depth to water table was approximately 43 inches (110 cm) from the soil surface at time of installation, with measurements taken at several locations to determine maximum feasible hole depth before the augured holes were back-filled with pure zeolite. Upon conduction of water to the surface (approximately one month after the columns were installed), creating a wetted area around the top of the columns, 6 species of 1-gallon containerized transplants [common to those planted under the irrigated regime of Study 1 (*Prosopis juliflora*, *P. pubescens*, *Acacia gregii*, *Lycium andersonii*, *Sphaeralcea ambigua*, and *Atriplex canescens*)] were planted within the wetted perimeter around each column (one row per species; 4 columns/plants per row). In addition, transplants were installed 18 inches (45 cm) lateral to the columns to determine if a zone of moisture was created outside of the column sufficient to support another plant at that distance.

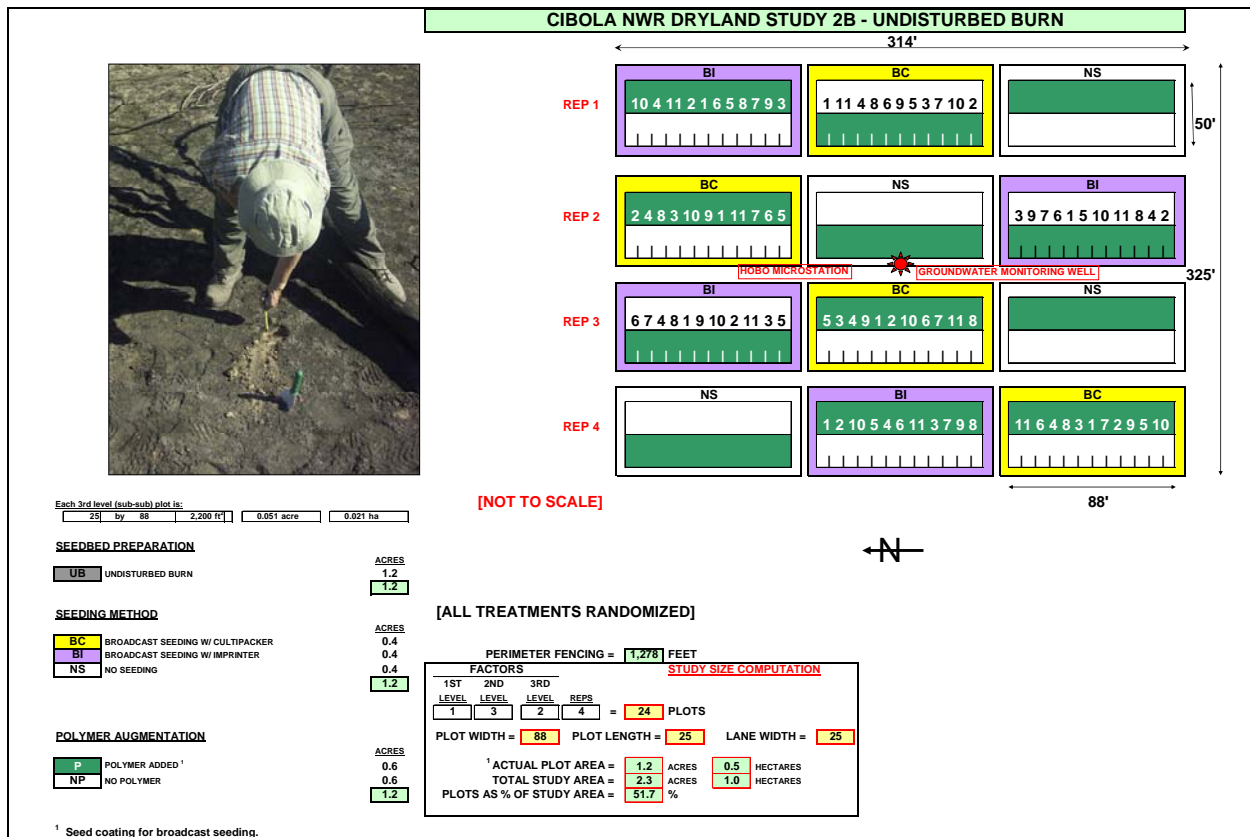

Figure 9. General layout of Demonstration Study 2B – Non-Irrigated, Cibola National Wildlife Refuge, Cibola, Arizona.

Estimated maximum total impact area for all studies: 11.6 acres (4.7 ha).

Mechanical Treatments

Mechanical treatments were used for quailbush removal (Demonstration Study 1) and burned saltcedar/mesquite biomass reduction (Demonstration Study 2), seedbed preparation, and/or placement and incorporation of soil polyacrylamide polymer amendments (Figure 11). These measures included root-plowing and root-raking, land imprinting, and cultipacking. These measures were evaluated for efficacy in a) creating seedbeds and planting mediums that are relatively clean of remnant saltcedar, mesquite and quailbush root material; b) creating soil surface micro-relief (micro-catchments) to enhance precipitation capture and retention in the rhizosphere of seeded/planted vegetation; c) reduction, redistribution, and/or dilution of salts in the upper soil profile and remnant ash from burned saltcedar leaf litter on the soil surface; d) creating more spatially uniform soil texture characteristics (in both depth and lateral extent) for improved planted vegetation adaptation; and e) proper depth placement of seed and transplant root materials. The land imprinter was acquired from the USBR Elephant Butte Division Office (New Mexico), including provision of transportation. Provision of Caterpillar tractor with root-plow and root-rake implements and operator was supplied by the USFWS Cibola National Wildlife Refuge.



Figure 10. Drill rig used to auger holes at the study site (Image A), and backfilling of holes with zeolite (Image B).



Figure 11. Demonstration study sites prior to mechanical clearing. Study Site 1 (Image A) was dominated by near-monotypic stand of quailbush (*Atriplex lentiformis*), with scattered honey mesquite (*Prosopis glandulosa*), screwbean mesquite (*Prosopis pubescens*), and rare saltcedar (*Tamarix ramosissima*) in the overstory. Study Site 2 (Image B) was dominated by a near-monotypic stand of saltcedar (*Tamarix ramosissima*), with minor understory components of arrowweed (*Pluchea sericea*), quailbush (*Atriplex lentiformis*), and honey mesquite (*Prosopis glandulosa*). Photos taken April 25, 2007.

Polyacrylamide Polymer Amendment

Polyacrylamide polymer (provided by Reforestation Technologies International, Salinas, CA) was used for enhancement of soil moisture retention and duration within the initial root development zone for the seeded/planted species. Polymer was a) incorporated into seed coatings for broadcast seeding treatments; b) applied as banded, dry granular applications into the drill row simultaneously with seed placement through the specialized cone-seeder mechanisms on drilled seedings; and c) applied as a biodegradable “teabag” (Reforestation Technologies International, Salinas, CA) for transplanted seedlings (Figure 12). Polymer application rate for all treatments was approximately equivalent to 15.3 lb ac⁻¹ (17.2 kg ha⁻¹). Seed coating for polyacrylamide polymer augmentation on broadcast seeding treatments was performed by Seed Dynamics, Inc. (Salinas, CA).



Figure 12. Polyacrylamide polymer augmentation of transplants in Demonstration Study 1. Polymer supplied by Reforestation Technologies International (RTI), Salinas, California.

Seeding/Planting

Revegetation methods included use of the following methods: a) Manual broadcasting; b) drilled seedings using a Kincaid/Truax™ research plot drill; and c) seedling transplants, planted manually. Seeding was conducted in conjunction with selected mechanical seedbed preparation treatments using a cultipacker (ring-roller) or imprinter to facilitate desired seed depth placement, and soil cover and compaction (i.e., soil-seed contact).

Species Selection

Emphasis was placed on testing native species (in conjunction with associated seeding/planting methodology) that best reflected environmental site adaptation, practical field applications by agencies and landowners, commercial availability, and cost-effectiveness.

Demonstration studies incorporated single-row (or broadcast block), single-species trials utilizing both seed and seedling transplants (Figure 13). Seeding rates for all seeding treatments were 30 seeds (pure live seed basis – PLS) per linear foot (30 cm) for drilled seedings or 60 seeds per square foot (0.09 m²) for broadcast seedings. All species were selected for optimum adaptation to interactions of climate, soil, salinity, competition from existing vegetation, and planned treatments, including pre-conditioning treatments (e.g., scarification for seed; selection for salinity tolerance and mycorrhizal inoculation potential [MIP] for transplants).

| SEEDING RATE COMPUTATION FOR EXPERIMENTAL PLOT DRILLING | | | | | | | | | | | | | | |
|---|--------|---|------|--------|----------------|---|------------|--|------------|---|----------------|---|---------|---|
| English Units | | Computation Basis - Seeds per Linear Foot | | | | | | | | | | | | |
| Data Source: | | L | | | | | | | | | | | | |
| No. Seeds per Foot: | 30 | <table border="1"> <thead> <tr> <th colspan="2">Treatments</th> </tr> </thead> <tbody> <tr> <td>Irrigation</td> <td>3</td> </tr> <tr> <td>Seeding Method</td> <td>1</td> </tr> <tr> <td>Polymer</td> <td>2</td> </tr> </tbody> </table> | | | | | Treatments | | Irrigation | 3 | Seeding Method | 1 | Polymer | 2 |
| Treatments | | | | | | | | | | | | | | |
| Irrigation | 3 | | | | | | | | | | | | | |
| Seeding Method | 1 | | | | | | | | | | | | | |
| Polymer | 2 | | | | | | | | | | | | | |
| Plot Row Length (ft): | 30 | | | | | | | | | | | | | |
| Row Spacing (in): | 18 | | | | | | | | | | | | | |
| Number Rows per Plot: | 3 | | | | | | | | | | | | | |
| Number of Treatments: | 6 | | | | | | | | | | | | | |
| Number of Replications: | 3 | | | | | | | | | | | | | |
| Mycor-rhizal | | | | | | | | | | | | | | |
| Common Name | Source | Transplant | Seed | rhizal | Family | Scientific Name | | | | | | | | |
| Inland saltgrass | | | √ | √ | Poaceae | <i>Distichlis spicata</i> | | | | | | | | |
| Alkali sacaton | | | | √ | Poaceae | <i>Sporobolus airoides</i> | | | | | | | | |
| Salt heliotrope | | √ | √ | | Boraginaceae | <i>Heliotropium curassivicum</i> | | | | | | | | |
| Desert globemallow | | √ | √ | | Malvaceae | <i>Sphaeralcea ambigua</i> | | | | | | | | |
| Catclaw acacia | | √ | √ | √ | Fabaceae | <i>Acacia gregii</i> | | | | | | | | |
| Alkal goldenbush | | √ | √ | √ | Asteraceae | <i>Isocoma acradenia</i> | | | | | | | | |
| Fourwing saltbush | | √ | √ | | Chenopodiaceae | <i>Atriplex canescens</i> | | | | | | | | |
| Anderson wolfberry | | √ | √ | √ | Solanaceae | <i>Lycium andersonii</i> | | | | | | | | |
| Honey mesquite | | √ | √ | √ | Fabaceae | <i>Prosopis glandulosa</i> | | | | | | | | |
| Velvet mesquite | | √ | √ | | Fabaceae | <i>Prosopis velutina</i> | | | | | | | | |
| Tornillo; screwbean mesquite | | √ | √ | √ | Fabaceae | <i>Prosopis pubescens</i> | | | | | | | | |
| Desert seepweed (AZ / CA) | | | √ | | Chenopodiaceae | <i>Suaeda suffrutescens / torreyana</i> | | | | | | | | |
| Iodinebush | | | √ | | Chenopodiaceae | <i>Allenrolfea occidentalis</i> | | | | | | | | |

Figure 13. Species selection and seeding data for Demonstration Studies 1 and 2, Cibola National Wildlife Refuge, Cibola, Arizona.

Native revegetation species were obtained from commercial sources. Species were selected from local (endemic) or regional origin where possible. Final species and cultivar selection was determined in consultation with local/regional cooperators (e.g., USFWS, Ducks Unlimited, NRCS Plant Materials Centers [Lockeford, CA; Tucson, AZ], USBR), and in relation to local harvest and commercial availability.

While honey mesquite (*Prosopis glandulosa*) is one of two endemic native mesquites for this Lower Colorado River locale and specific site within Cibola NWR, velvet mesquite (*Prosopis velutina*) was used in lieu of honey mesquite for the seeded portions of the demonstration studies because of unavailability of the latter species from commercial sources and from local harvest at the time of seeding. Velvet mesquite is considered a viable proxy for honey mesquite as an indicator species in terms of response to specific treatments applied in these studies. Screwbean mesquite (*P. pubescens*), the other endemic native mesquite, was available commercially in seed and transplant materials, and was used in these studies without proxy.

Herbivory Protection

Transplant materials were protected (to the extent feasible) from livestock and wildlife herbivory by erection of rabbit-proof fencing (Figure 14), and application of DeerGuard™ chemical repellent (Treessentials Company, St. Paul, MN) to planted transplant stock. Gated, rabbit-proof fencing (using woven “chicken-wire up to 30” tall, and buried 6” deep) was installed around the

perimeter of Studies 1 and 2A. Seed predation and herbivory threat from rabbits in these study locations was considered paramount over threat from deer and other ungulates at this locale.

Fencing was not installed around Study 2B, given the negligible probability of intense rabbit herbivory in such an area devoid of predator cover (open exposure within the existing, undisturbed burn area); its remoteness to irrigated agricultural production fields and cover; and funding and staff limitations. DeerGuard™ was applied both pre- and post-plant to the transplant materials, and is recommended for re-application in spring, 2009 to further enhance deterrence from large animal herbivory.



Figure 14. Rabbit-proof fencing with access gate installed around the perimeter of Demonstration Studies 1 and 2A, Cibola National Wildlife Refuge, Cibola, Arizona. The fencing was successful in excluding rabbits from study sites, but was also successful at retaining rabbits within that were trapped by the fencing installation – particularly for Study 1.

Irrigation Application

Portions (two-thirds of the plot area) of Demonstration Study 1 was irrigated under varying duration for comparison with adjacent plots that were non-irrigated (Figure 15). The Department of Bioagricultural Science and Pest Management, Colorado State University, and the USBR (Denver Technical Service Center) supplied irrigation equipment (sprinkler pipe, feeder and suction pipe, valves, and pump) and irrigation system installation, layout and testing. The Cibola NWR provided an operator for application of planned irrigation regimes (including irrigation set

timing, amounts, and duration). A flow meter was installed inline with the irrigation system on the output side of the irrigation pump. Readings were taken before and after irrigation events to estimate actual amount of irrigation water supplied to test plots.

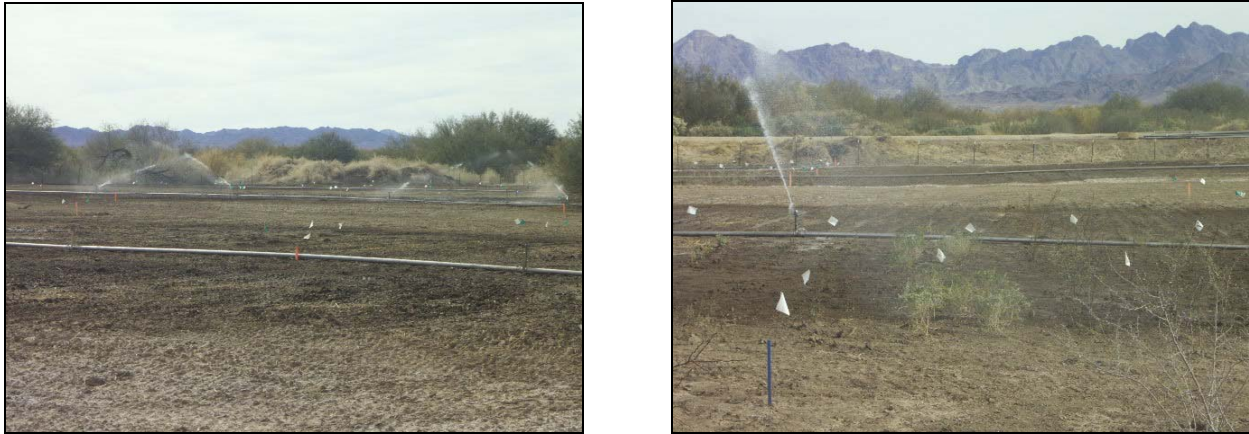

Figure 15. Sprinkler irrigation system used for irrigated portions of Demonstration Study 1, Cibola National Wildlife Refuge, Cibola, Arizona.

The system is comprised of 3” (7.6 cm) diameter aluminum, hand-laid irrigation sprinkler pipe aligned centrally along the long axis centerline within each irrigation set (paired replications; see attached plot diagram, worksheet 1) (Figure 15). The system is pressurized by a Honda WT30X™ gasoline-powered centrifugal pump with 3-in (7.6 cm) inlet and outlet, producing a maximum of 319 gpm (1,207 lpm) output at 39 psi. Each set can be operated individually or in tandems of 2 or 3 sets using valves incorporated in the main feeder line. Sprinkler heads are Rainbird™ (or similar) R65 heads incorporating 9/32” (0.28 inch; 0.71 cm) nozzles, achieving average radii of 35-40 feet (10.6 – 12.1 m) coverage bi-directionally from the irrigation set centerline). All plots are irrigated equally within the season (including control plots with no seeding). However, the supplemental, short-duration irrigation treatment (pink-bordered plots on the attached diagram, Figure 7) will cease upon emergence and early growth (3-4 leaf stage) of seeded species, or approximately March 30.

Irrigation amounts, timing, and duration for the seeded/planted vegetation within Demonstration Study 1 was determined based on meeting minimum evapotranspiration needs of the newly seeded/planted materials in order to prevent moisture stress during germination, adventitious root development and transplant acclimation and root extension (as appropriate). Output at each sprinkler head at 35-39 psi is 12 gpm (45 lpm). Each block of 11 irrigated plots (total = 1,650 ft²; 0.04 ac; 0.015 ha) conceptually receives (on average, across the block) approximately 0.25 week⁻¹ (0.64 cm week⁻¹) or 0.021 ac-ft week⁻¹ over an irrigation set time of approximately 1.2 hours. This application rate represents approximately double (2X) the long-term mean weekly precipitation received at this site, during the December through March “rainy season”.

This application rate is intended to keep the plants (seeded and transplanted) out of moisture stress, but not over-watered, such that root systems still develop vertically into deeper soil horizons in order to maximize stress-tolerance and survival as they mature and enter the summer season. Instructions on operation, maintenance and trouble-shooting of the irrigation system were provided to Cibola NWR staff, who will conduct and oversee weekly (as needed) irrigation

treatments, as prescribed above. Irrigation supply for Demonstration Study 1 was provided by means of a USFWS water right, enabling pumping (via portable, gas-powered pump apparatus) directly from the concrete-lined ditch lateral directly adjacent to the study site. The USFWS confirmed this water right, and agreed to provide such water for Demonstration Study 1. Total annual water requirement for Demonstration Study 1 is 2.5 ac-ft. Demonstration Study 2 was not irrigated.

Climate Monitoring

Each demonstration study site was instrumented with a HOBO Micro-Station™ (Onset Computer Corporation, Pocasset, MA) with soil moisture, soil temperature, and ground-level air temperature and humidity sensors (Figure 16). These provide real-time monitoring of soil and sub-canopy variables under the various irrigation treatment regimes during the life of the project. One set of sensors is located centrally per site as follows:

- Study 1 – irrigated portion
- Study 1 – dryland portion
- Study 2A – root-plowed
- Study 2B – undisturbed burn

Additionally, a HOBO Weather Station™ (Onset Computer Corporation, Pocasset, MA) was installed adjacent to Study 1 to collect on-site weather data in order to supplement and refine the accuracy of the nearby NOAA/WRCC weather stations for the study sites (Figure 16). All data are electronically downloaded and transmitted on a minimum weekly basis via HOBOLink™ software and T-Mobile wireless phone transmission to USBR computers, with subsequent compilation, analysis and correlation to study results. The data may also be downloaded via manual (cable connection) download to a PDA or laptop computer in the field. Study climatic and soil variables include:

- Precipitation
- Air temperature
- Relative humidity
- Wind speed and direction
- Soil moisture and temperature
- Total incoming (global) radiation
- Photosynthetically active radiation (PAR)



Figure 16. Remote weather stations installed on the burn revegetation demonstration studies, Cibola National Wildlife Refuge, Cibola, Arizona. A. HOBOT MicroStation™ installed on all three study sites, with sensors for air temperature and humidity at 60 cm height, and soil moisture and temperature at 15 cm soil depth. B. HOBOT Weather Station installed adjacent to Demonstration Study 1, with a full array of sensors as described in the narrative text.

Herbicide Application

Ongoing control of saltcedar sprouts following fire or mechanical treatment will be conducted via basal bark treatment using triclopyr in a vegetable oil carrier [see Study Plan (November, 2007), Appendix 4, Pesticide Use Proposal TSC-KL-08-01, for treatment selection, extent, objectives, chemicals and application techniques]. Secondary invasive species will be similarly controlled using labeled herbicides appropriate for the target species and land use type, with associated Pesticide Use Proposal(s) developed for the secondary target species prior to application. Applied control and revegetation on demonstration study sites will be designed, monitored and maintained with respect to a) other aggressive weeds that may be present and potentially increase in the absence of saltcedar; and b) the practical application of control measures in relation to accepted IPM techniques and habitat restoration objectives. Strict adherence to applicable laws, regulations and product label requirements will be practiced, with primary consideration given to minimizing impacts to non-target vegetation and maintenance of water quality. Selected herbicide products will be currently labeled for use on range and pasture or non-cropland in Arizona. Pesticide Use Proposal(s) will be submitted for approval to USFWS and USBR prior to treatment.

Initial herbicide treatment (now projected for spring, 2009) will be manually applied within demonstration study plots using backpack sprayers and accepted basal bark application techniques. Subsequent control of saltcedar will be maintained herbicidally on treated plots over the duration of the study via spot treatment using backpack sprayers, or as situations indicate

following revegetation treatments, carpet roller or rope wick application (dependent upon plant densities, prevalence of non-target vegetation, and cost effectiveness).

Compliance Planning

The U.S. Fish and Wildlife Service (Albuquerque Region 2, and Cibola National Wildlife Refuge) were jointly responsible for conducting all compliance planning, documentation, and obtaining all approvals pertaining to requirements of the National Environmental Policy Act (NEPA) and Endangered Species Act (ESA), as appropriate. It was anticipated that the project would qualify under Categorical Exclusion provisions of NEPA, Sections 9.4.A.3 (Research Activities) and/or 9.4.B.1 (Routine Planning Investigation Activities) because of its demonstration purpose and limited physical impacts within the regional project area. The project was also anticipated to receive exemption from NPDES requirements using the same justifications.

Implementation

All studies were installed from early- to mid-December, 2007. Timing of the treatments was delayed and treatment installation sequencing was modified to allow adequate drying of the surface soils for drilling of seed following the intense rainstorm that deposited approximately 2” (5 cm) of rain over the weekend of December 1-2. Overall, approximately 90% of the planned treatments were applied in terms of number of plots actually treated, as well as completion considered within the context of intended design, need, priority and applicability.

Results – 2008

Post-treatment monitoring

Data were collected from Demonstration Study 1 on June 11 and September 24, 2008. Plant counts for transplants were performed by species in each plot. No statistical comparisons between species were performed because of intrinsic differences in biology, life history, and growth form. Rather, the individual plant species were utilized as independent indicator or “test” species in evaluating treatment effects and interactions. The two native forb species failed to establish for reasons unrelated to treatment, and were therefore not targeted for data collection or analysis. Salt heliotrope (*Heliotropium curassivicum*) succumbed to freeze mortality immediately after planting when nighttime low temperatures fell below 32° F. Desert globemallow (*Sphaeralcea ambigua*) exhibited 100% mortality because of complete rabbit herbivory immediately after planting. Data were collected on the remaining 6 transplant species.

Transplant survival was the lone monitoring variable in 2008 because of staff and funding limitations. Additional variables for both transplanted and seeded species will be conducted in 2009 (e.g., establishment success in relation to seeding rate; vigor variables; cover; seedling recruitment; etc.). Increased number of variables will increase sample size [i.e., measured value(s) per plant vs. value(s) per plot], permitting estimates of, and accountability in statistical analysis for within-plot variability. With survival, this variable is represented by one value (%) per plot, decreasing sample size and increasing variability. As a result, determination of significant differences was more limited, although observational, positive trends in treatment results were strong.

In rare instances, survival for a given species in September is depicted as slightly exceeding that of survival results from June for the same species. This is attributed to some plants being deemed as non-surviving in June because of apparent absence of leaves and other apparent indications of mortality. In reality, however, the plants were alive and produced foliage in response to remnant vitality that was recorded in September, although not apparent in June. These cases were rare, and differences slight, yielding negligible affects for data analysis and interpretation.

No data collection was conducted on seeded species in Studies 1, 2A, and 2B because of poor emergence and establishment in 2008 due to negligible precipitation (1.38 in [3.5 cm], January through August, 2008) (Figure 17); seed dormancy mechanisms; and otherwise poor response to irrigation after seeding. Better results anticipated in 2009 with higher precip and dormancy release.

Post-treatment monitoring is planned to be conducted (as a minimum) once per year during the three-year intensive monitoring period (2008-2010) in late spring to early summer (March - May), subject to funding availability. Initial, measured field variables for use in evaluating treatment responses will include:

Soils

Using core sampling techniques, demonstration study area soils will be systematically sampled (starting in 2009) for parameters of:

- Organic matter.
- Fertility (macro- and micro-nutrients; surface layer only).
- Salinity (EC/SAR; surface and subsoil).
- Reaction (pH).

An EM38 electrical conductivity meter will also be used to indirectly determine soil EC down to 36-inch (91 cm) soil depth for correlation with core sample values.

Groundwater

A minimum of four (4) seasonal (quarterly) groundwater depth and quality samples (via use of Troll 9000™, HydroLab™, or similar test probe), including:

- Ground water depth
- Conductivity
- pH
- Alkalinity

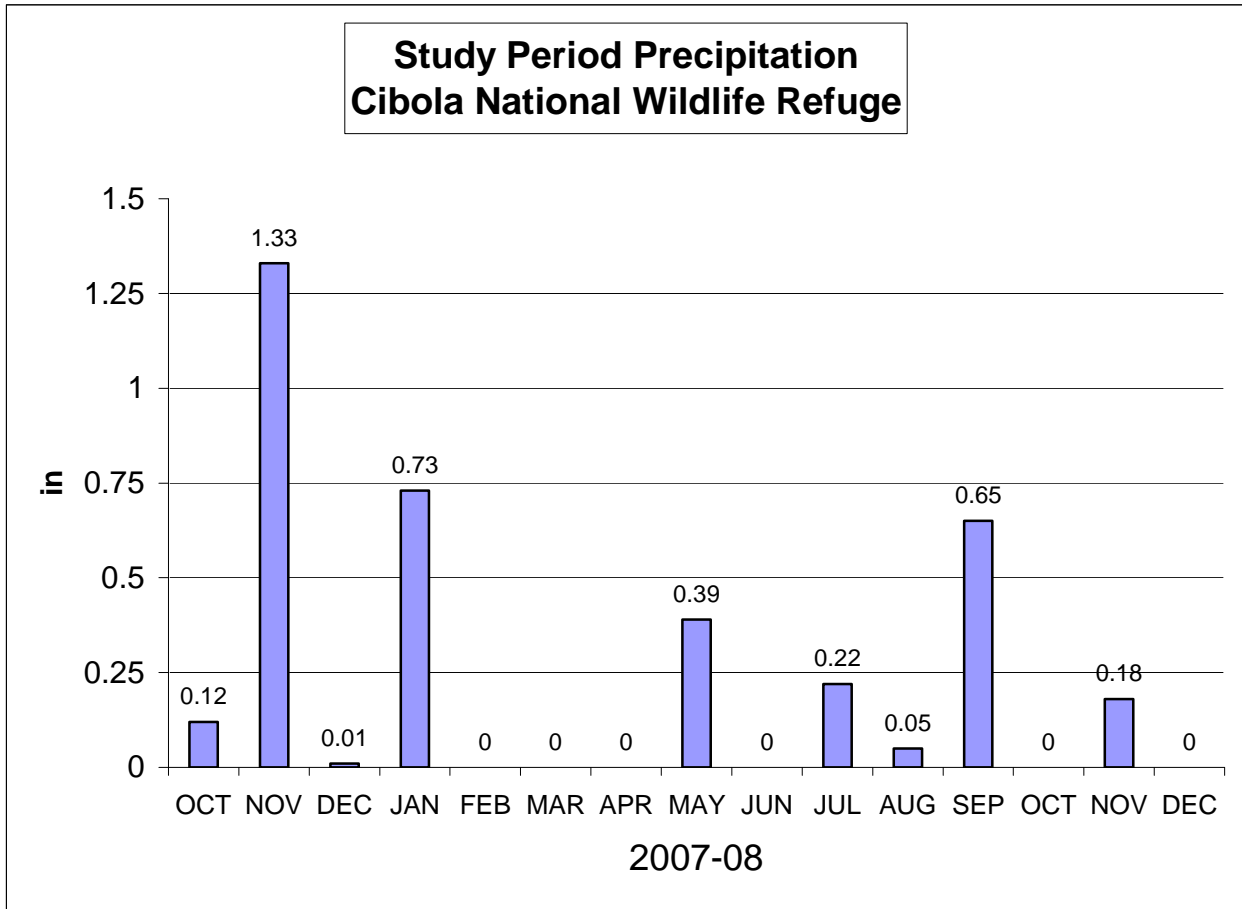

Figure 17. Precipitation received at the study sites, 2007-08, derived from the on-site HOBO Weather Station. Burn revegetation demonstration studies, Cibola National Wildlife Refuge, Cibola, Arizona (installed December 17, 2007).

Vegetation

- Survival.
- Species frequency and percent stand relative to seeding or planting rate.
- Basal and canopy cover, seeded and non-seeded.
- Vigor Index (function of culm and leaf height, seedhead production, and biomass).
- Bare ground and litter.

{Note: Revision of treatment response monitoring variables may occur, dependent upon pre-sampling data analysis, treatment efficacy, and further input from cooperators.}

Irrigation Duration

No comparisons for irrigation effect were made between monitoring periods because effects were uniform across irrigation levels for both data collection periods, and in the interest of providing concise results with clear and practical interpretation and applicability. Therefore, significant differences for irrigation treatments represent September 2008 results only.

Full irrigation yielded increased transplant survival in comparison with partial irrigation, but was statistically similar with non-irrigated treatments across species (Figure 18; Table 4). Full irrigation produced observable trends of increased survival for most species, although these differences were not consistently shown to be statistically significant because of relative small sample sizes, particularly for certain individual species. Full irrigation was statistically superior to partial (early-season only) irrigation for all species considered together (pooled – “ALL SPECIES”), catclaw acacia, honey mesquite, and Anderson wolfberry. However, for these same species (or species grouping), there was no significant difference in transplant survival between full irrigation and no irrigation – a finding also holding true for all remaining species, where no significant differences were apparent between any of the three irrigation duration treatment levels. These trends in response to irrigation treatment were largely consistent across monitoring periods (June vs. September, 2008) for all species.

Treatment Results

Seeded Species

No data collection was conducted on seeded species because of lack of emergence and establishment in 2008 (see **Post-Treatment Monitoring**, above). There was limited establishment of seeded desert seepweed (*Suaeda moquinii*; SUMO), fourwing saltbush (*Atriplex canescens*; ATCA), and alkali sacaton (*Sporobolus airoides*; SPAI), but insufficient to justify data collection in 2008. Germination and emergence was not observed for other seeded species. Seeded plots will be monitored in 2009 following exposure to a full precipitation season (November – March) and anticipated dormancy release and increased capacity for seed imbibition for many of the species.

Transplanted Species

For the measured transplant species, overall mean plant survival (across all treatments) for the initial 2008 establishment year (based on September 2008 data collection) was 20.9%, and ranged from 1.4% (*Isocoma acradenia*) to 44.2% (*Atriplex canescens*). Mean plant survival within individual treatment levels (or combinations of treatments), however, exhibited a much wider range of values, with survival ranging from a low of 0.0% under several treatment level combinations to as high as 77.4% under combined full irrigation and polymer augmentation for *Atriplex canescens* (Figure 20). Species survival response to irrigation duration was relatively variable, but in general showing positive response to full irrigation. Response to polymer augmentation was much more uniform in terms of consistency across species and in continuation of response over time. Specific responses to treatment types and levels, and to interactions between treatment types and levels, are summarized below.

Table 4. Treatment responses of native transplant species, June and September, 2008, for Demonstration Study 1, Cibola National Wildlife Refuge burn revegetation project, Cibola, Arizona.

| SPECIES | VARIABLE | LEVEL | Survival (%) | | |
|--|----------------------|---------|----------------------------|----------------------------------|----------------------------------|
| | | | June 2008 | Sept 2008 | |
| <i>ALL SPECIES</i> <i>(Pooled)</i> (n = 96) | Irrigation Duration | FULL | 34.0 b ¹ | 31.6 b | |
| | | PARTIAL | 14.1 a | 10.5 a | |
| | | NONE | 24.7 ab | 20.5 ab | |
| | | | | F=4.20 P=0.018 LSD=12.8; 14.3 | F=6.79 P=0.002 LSD=11.8; 13.2 |
| | Polymer Augmentation | POLYMER | 24.6 a | 25.9 a | |
| | | NONE | 23.9 a | 15.8 a | |
| | | | F=0.02 P=0.898 LSD=11.1 | F=3.73 P=0.057 LSD=10.2 | |
| <i>Acacia gregii</i> Catclaw acacia (n = 16) | Irrigation Duration | FULL | 12.8 b | 10.3 b | |
| | | PARTIAL | 6.4 ab | 1.3 a | |
| | | NONE | 0.0 a | 0.0 a | |
| | | | | F=2.88 P=0.107 LSD=9.9; 11.1 | F=5.65 P=0.026 LSD=6.9; 7.8 |
| | Polymer Augmentation | POLYMER | 9.4 a | 5.1 a | |
| | | NONE | 3.4 a | 2.6 a | |
| | | | F=2.10 P=0.181 LSD=8.6 | F=0.79 P=0.398 LSD=6.0 | |
| <i>Atriplex canescens</i> Fourwing saltbush (n = 16) | Irrigation Duration | FULL | 53.9 a | 48.7 a | |
| | | PARTIAL | 39.7 a | 33.3 a | |
| | | NONE | 59.6 a | 53.9 a | |
| | | | | F=0.45 P=0.649 LSD=47.8; 53.5 | F=1.29 P=0.321 LSD=24.4; 27.3 |
| | Polymer Augmentation | POLYMER | 55.6 a | 64.1 b | |
| | | NONE | 46.6 a | 26.5 a | |
| | | | F=0.20 P=0.663 LSD=41.4 | F=13.69 P=0.005 LSD=21.1 | |
| <i>Isocoma acradenia</i> Alkali goldenbush (n = 16) | Irrigation Duration | FULL | 2.6 a | 0.0 a | |
| | | PARTIAL | 3.9 a | 2.6 a | |
| | | NONE | 3.9 a | 1.9 a | |
| | | | | F=0.16 P=0.856 LSD=6.2; 6.9 | F=0.62 P=0.558 LSD=4.9; 5.5 |
| | Polymer Augmentation | POLYMER | 3.0 a | 3.0 a | |
| | | NONE | 3.9 a | 0.0 a | |
| | | | F=0.11 P=0.748 LSD=5.4 | F=2.12 P=0.179 LSD=4.3 | |

Table 4 (continued). Treatment responses of native transplant species, June and September, 2008, for Demonstration Study 1, Cibola National Wildlife Refuge burn revegetation project, Cibola, Arizona.

| SPECIES | VARIABLE | LEVEL | Survival (%) | | |
|---|---------------------|----------------------|----------------------|----------------|-----------------|
| | | | June 2008 | Sept 2008 | |
| <i>Prosopis glandulosa</i> Honey mesquite (n = 16) | Irrigation Duration | FULL | 56.4 b ^{1/} | 51.3 b | |
| | | PARTIAL | 18.0 a | 15.4 a | |
| | | NONE | 26.9 ab | 15.4 a | |
| | | | | F=2.63 P=0.126 | F=11.39 P=0.003 |
| | | | | LSD=38.0; 42.5 | LSD=19.2; 21.5 |
| | | | | | |
| | | Polymer Augmentation | POLYMER | 26.9 a | 27.8 a |
| | | | NONE | 40.6 a | 26.9 a |
| | | | | F=0.75 P=0.410 | F=0.01 P=0.917 |
| | | | LSD=32.9 | LSD=16.6 | |
| <i>Prosopis pubescens</i> Screwbean mesquite (n = 16) | Irrigation Duration | FULL | 27.0 a | 27.0 a | |
| | | PARTIAL | 9.0 a | 9.0 a | |
| | | NONE | 32.7 a | 28.9 a | |
| | | | | F=1.27 P=0.328 | F=1.49 P=0.275 |
| | | | | LSD=30.6; 34.2 | LSD=22.6; 25.3 |
| | | | | | |
| | | Polymer Augmentation | POLYMER | 21.4 a | 23.1 a |
| | | | NONE | 24.4 a | 20.1 a |
| | | | | F=0.06 P=0.819 | F=0.10 P=0.756 |
| | | | LSD=26.5 | LSD=19.6 | |
| <i>Lycium andersonii</i> Anderson wolfberry (n = 16) | Irrigation Duration | FULL | 51.3 b | 52.6 b | |
| | | PARTIAL | 7.7 a | 1.3 a | |
| | | NONE | 25.0 ab | 23.1 ab | |
| | | | | F=2.49 P=0.138 | F=5.93 P=0.023 |
| | | | | LSD=42.3; 47.3 | LSD=33.2; 37.2 |
| | | | | | |
| | | Polymer Augmentation | POLYMER | 31.6 a | 32.5 a |
| | | | NONE | 24.4 a | 18.8 a |
| | | | | F=0.17 P=0.690 | F=0.98 P=0.349 |
| | | | LSD=36.6 | LSD=28.8 | |

^{1/} Values within the same variable and column (date) exhibiting different letters are significantly different at P=0.05 (Fisher's Protected Least Significant Difference test). Values represent means pooled across the other variable. F-values derived from 2-way ANOVA with covariates (Program 2V; BMDP Statistical Analysis Package; Dixon 1992).

Although not statistically significant at the sample sizes constrained by survival determinations as the lone measurement variable within the 2008 monitoring periods, observed trends in the data suggest that fourwing saltbush and screwbean mesquite benefit from absence of irrigation (Figure 18; Table 3). Survival of fourwing saltbush under no irrigation exceeded survival under full irrigation by 10% when analyzed (pooled) across polymer treatments, while screwbean mesquite survival varied from 7% to 21% greater for September and June monitoring periods, respectively, under the same treatment level comparison. Conversely, other species such as honey mesquite, catclaw acacia, and Anderson wolfberry appeared to greatly benefit from full irrigation when analyzed across polymer treatments, ranging from multiplication factors of 2-3X,

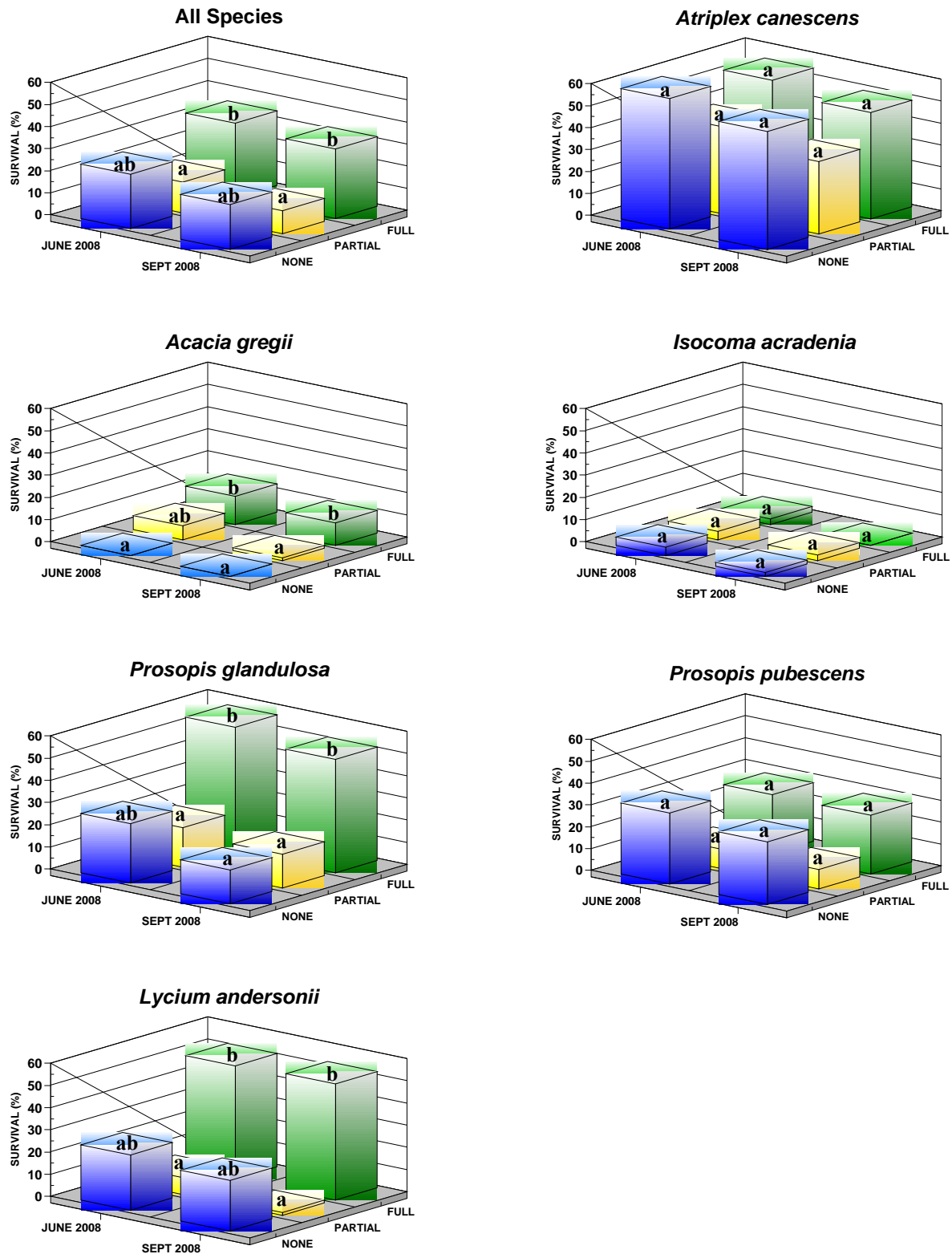

Figure 18. Univariate treatment responses of transplanted species to irrigation duration across monitoring dates. Burn revegetation demonstration studies, Cibola National Wildlife Refuge, Cibola, Arizona (installed December, 2007). Individual bars within monitoring dates having different letters are significantly different at $P=0.05$, using Fisher's Protected Least Significant Difference test (LSD) (see Table 3 for LSD, F-, and p-values).

10-13X and 2-3X for these species, respectively, above both non-irrigated and partially irrigated treatment levels. Response to irrigation treatment for alkali goldenbush was variable and non-significant across monitoring periods, in part constrained by low overall survival (maximum survival of 5.1%, with mean survival across all treatments of 1.4%).

In general, partial irrigation treatment (i.e., limited duration; early season only) was consistently inferior to either full irrigation or no irrigation, with the lone exceptions being catclaw acacia and alkali goldenbush. However, in these species, there was no significant difference between the partial and no irrigation treatment levels; results are variable between monitoring periods (alkali goldenbush only); and results may be confounded by the relatively lower survival of these two species under all treatments.

Polymer

Survival results demonstrated a positive, uniform trend in response to polymer treatment, although most responses were not significant because of constraints imposed by small sample size for survival determinations inducing increased variability. Polymer significantly increased survival for *Atriplex canescens*, particularly for the September monitoring period, yielding a 2.5-fold increase over no polymer (64.1% vs. 26.5%) (Figure 19; Table 3). Significance was nearly achieved for all species (pooled) in September, achieving a p-value of 0.057, in large part derived from the very highly significant difference between polymer treatment means for fourwing saltbush.

Despite the relative absence of significant findings, the overall consistent trend in the data suggests strongly that polymer provided distinct transplant survival advantage for all species (Figure 19; Table 3). These trends are not as uniform in the June data, where certain species showed initially higher survival under absence of polymer augmentation (e.g., alkali goldenbush, honey mesquite, and screwbean mesquite; ranging from 14 to 51% higher). However, the positive trend across essentially all species is particularly apparent in the September data, where polymer augmentation routinely increased mean survival over time by almost 2-fold in many cases. These trends are particularly apparent when displayed graphically (Figure 19).

Figure 20 provides a graphical, multivariate depiction of the results for all species across both irrigation duration and polymer augmentation treatments for the September 2008 monitoring period. Similar to results shown in Table 3 and Figures 18 and 19, survival is generally increased under full irrigation and polymer augmentation, with polymer providing sustainable positive effect on survival over time. This holds true for all species except perhaps for screwbean mesquite and fourwing saltbush, which is consistent with findings under irrigation duration alone, suggesting that these two species have superior capabilities for dryland survival without supplementation from either free water (irrigation) or polymer-bound water.

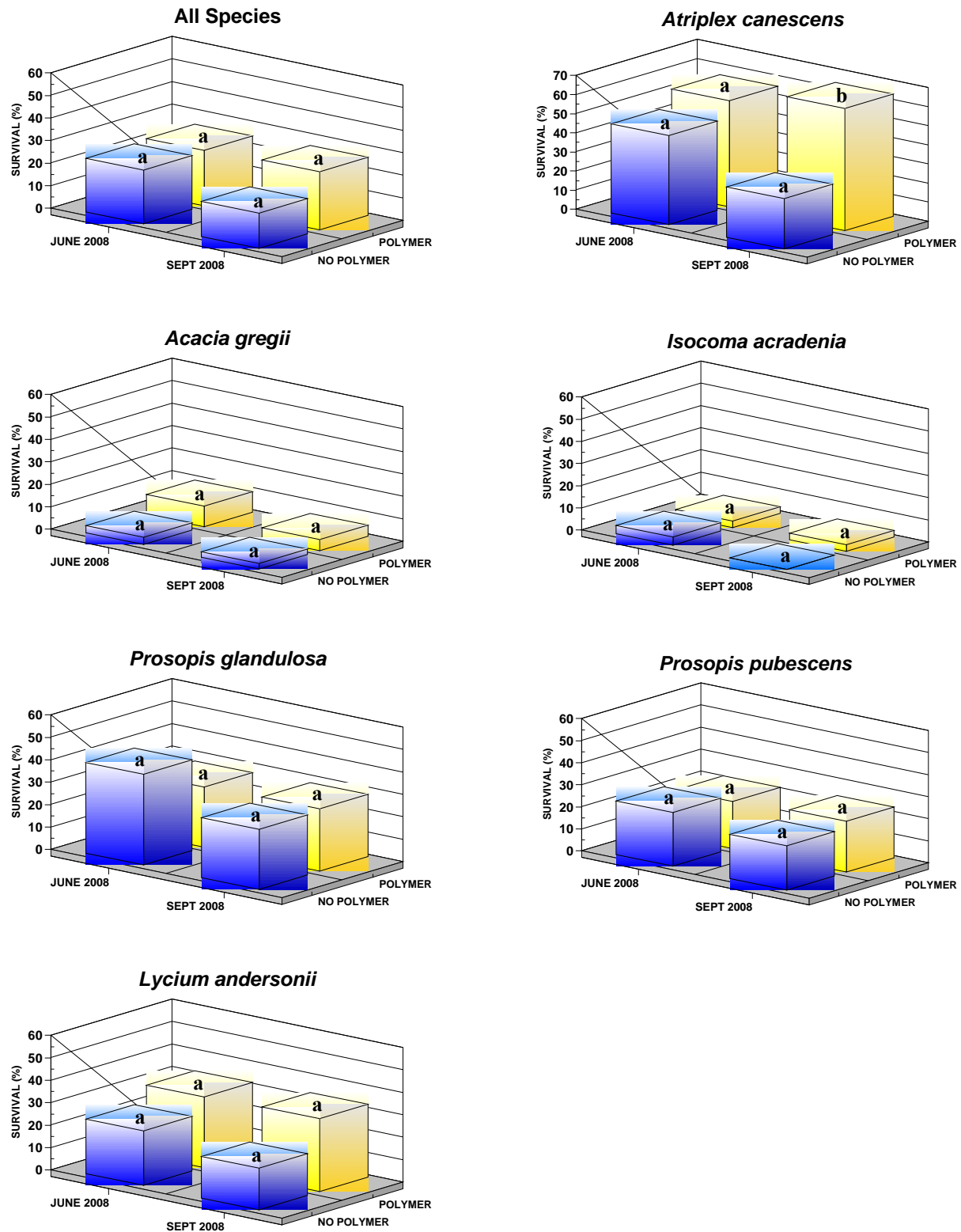

Figure 19. Univariate treatment responses of transplanted species to polymer augmentation across monitoring dates. Burn revegetation demonstration studies, Cibola National Wildlife Refuge, Cibola, Arizona (installed December, 2007). Individual bars within monitoring dates having different letters are significantly different at $P=0.05$, using Fisher's Protected Least Significant Difference test (LSD) (see Table 3 for LSD, F-, and p-values).

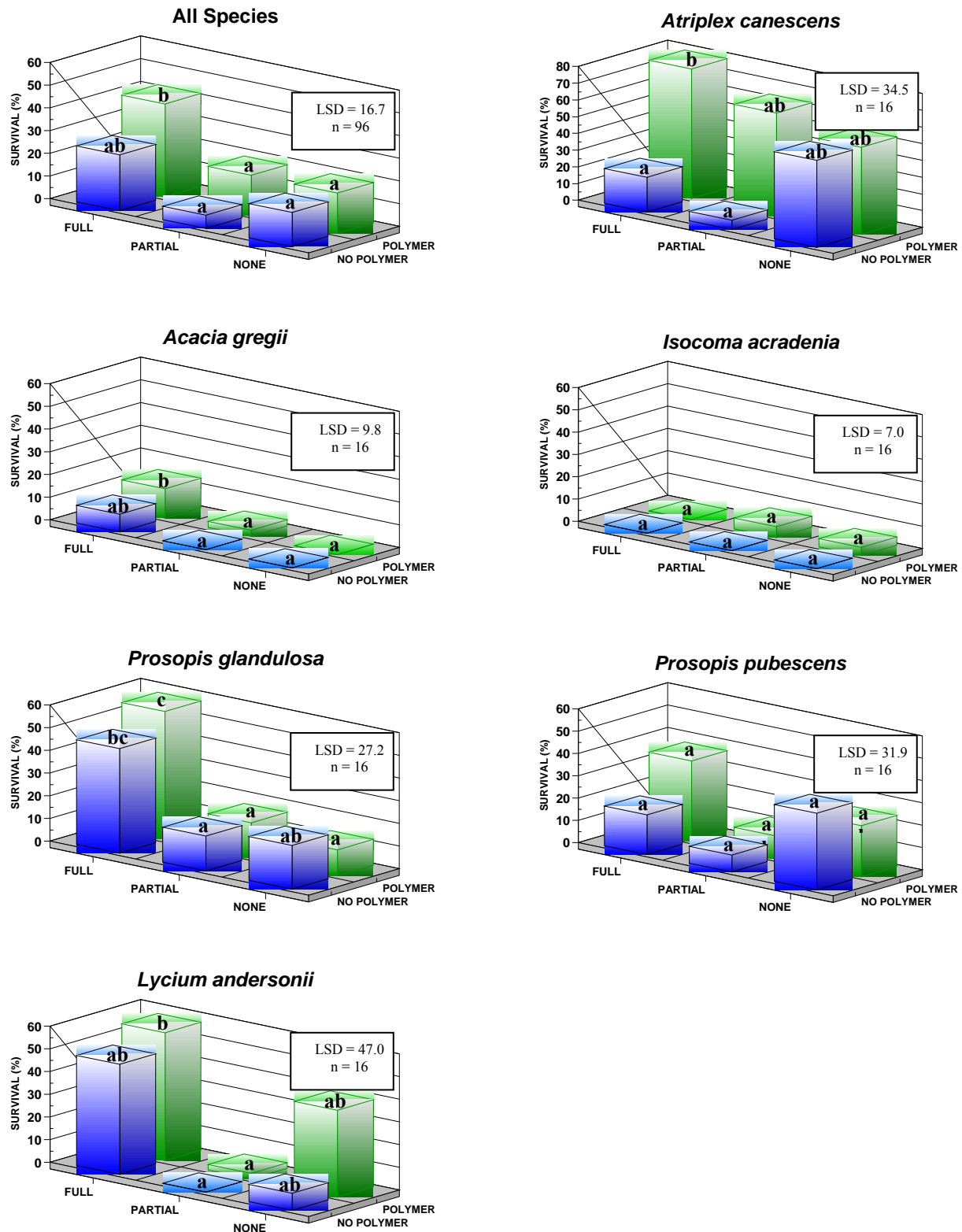

Figure 20. Multivariate treatment responses of transplanted species to irrigation duration and polymer augmentation (September 2008 data only). Burn revegetation demonstration studies, Cibola National Wildlife Refuge, Cibola, Arizona (installed December, 2007). Individual bars having different letters are significantly different at P=0.05, using Fisher's Protected Least Significant Difference test (LSD).

Zeolite Columns

Transplant survival in zeolite was consistently improved for certain species – fourwing saltbush, honey mesquite, and screwbean mesquite (Figure 21). Other species planted in this demonstration (catclaw acacia, desert globemallow, and Anderson wolfberry) did not survive regardless of treatment, primarily because of intense rabbit herbivory in the demonstration site locale that was proximal to undisturbed cover immediately outside of the study perimeter. As a result, no comparisons could be made for these latter species.

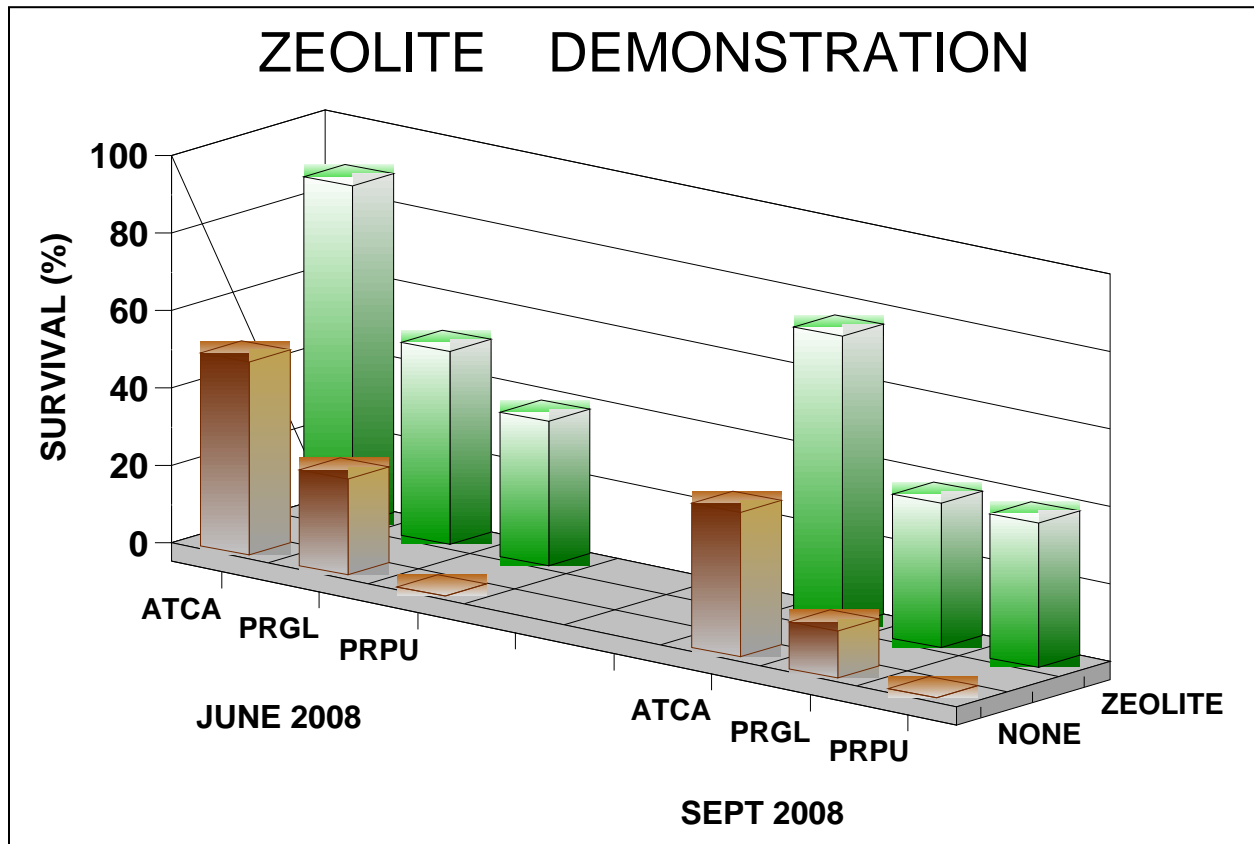

Figure 21. Treatment responses of selected transplanted species to zeolite augmentation (September 2008 data only). Burn revegetation demonstration studies, Cibola National Wildlife Refuge, Cibola, Arizona (installed December, 2007). Data were not analyzed statistically. Species tested were a subset of the full species palette for Study 1. Species key: ATCA = *Atriplex canescens* (fourwing saltbush); PRGL = *Prosopis glandulosa* (honey mesquite); PRPU = *Prosopis pubescens* (screwbean mesquite).

For fourwing saltbush and honey mesquite, zeolite increased survival over non-zeolite plantings (non-augmented native soil), ranging from 75 – 300% across both monitoring periods. Screwbean mesquite survival improved to 38%, compared to 0%, under zeolite treatment.

Replication and Covariate Effects

Initial ANOVA data analysis runs (using Program 2V; BMDP Statistical Software, Inc., Los Angeles, Calif.; Dixon 1992) included replication as a separate treatment (grouping) variable to determine replication (blocking) effect independent from treatment effects. Honey mesquite and

Anderson wolfberry were the only species to indicate significant replication effect. Because of this limited replication effect among all species evaluated, and in order to maximize degrees of freedom and sample size as part of the ANOVA procedure, the analyses were repeated with adjustment of actual treatment effects using replication as a covariate factor. Covariate effect was again significant for honey mesquite and Anderson wolfberry.

For these two species, survival was increased on a gradient toward Replication 1, typically by a factor of 2-3X between lowest and highest survival (mean survival: PRGL – Replication 1 = 38.5%; Replication 2 = 26.9%; Replication 3 = 17.3%; LYAN - Replication 1 = 48.7%; Replication 2 = 20.5%; Replication 3 = 0.0%). Much of this replication (covariate) effect for Anderson wolfberry was derived from the fact that 0% survival occurred in Replication 3, thereby introducing additional significance because of the skewed data set. For full and partial irrigation duration treatments, Replication 1 occurred on the eastern sides of each respective treatment level. As such, Replication 1 in each case may have experienced increased moisture accumulation because of surface runoff from irrigation and precipitation (due to topographical gradient) and from sub-irrigation potential in the form of seepage and slightly shallower groundwater depths in closer proximity to the irrigation ditch and leaking gate(s). However, all other species under this same scenario did not exhibit significant replication effects as a covariate. Even though replication effects were significant in two transplant species, many significant treatment effects remained for irrigation duration and polymer augmentation following statistical isolation, extraction of variability, and adjustment of treatment means associated with replication effect through the ANOVA procedure. This emphasizes the magnitude of treatment effects that were still evident after removal of replication effects through covariate analysis.

Interaction Effects

For all species (individual and pooled), and within and across all treatments and replications, there were no significant interaction effects between irrigation duration and polymer augmentation.

Discussion

Treatments

Interpretation of the irrigation effect is problematic, given the inferior performance of the partial irrigation treatment in comparison with no irrigation (Table 3; Figure 18). The cut-off date for irrigation that characterized “partial” (limited duration) irrigation may have occurred in 2008 at a critically early point in time when root systems were not yet fully established, sufficient to maintain moisture and nutrient uptake (i.e., survival) on their own without irrigation assistance. Additionally, significant portions of the non-irrigated sections of the study were essentially sub-irrigated because of adjacent drainage, as well as partially shaded from afternoon sun by extant, undisturbed honey and screwbean mesquite trees.

With larger sample sizes, indications are strong that polymer would significantly benefit all species. This should be especially evident in 2009-10 data collection, when several other growth and vigor variables will be added to survival for measurement of individual plant responses. Cross-linked polyacrylamide polymer (applicable for water capture, retention and release for

plant uptake – as opposed to linear-linked polymer, which is more suitable for earthen sealing and biocontaminant extraction purposes) is available commercially from several sources (for example: HydroSource™, Castle International Resources, Sedona, AZ; DriWATER™, DriWATER, Inc., Santa Rosa, CA). It has had broad, economical use in horticulture, silviculture, agroforestry, arboriculture, and windbreak applications for decades, and has comparatively only recently been expanded in its application to establishment of native species used for disturbed land restoration in natural areas under dryland scenarios.

Particularly note in the data how polymer sustained higher rates of survival over time (June to September monitoring periods). Although few significant differences were detected because of small sample sizes, trends in the data suggest strongly that polymer was instrumental in increasing survival in nearly all species tested. While initial monitoring (June 2008) indicated that survival of some species without polymer augmentation was equal to or exceeded survival under polymer augmentation (e.g., honey mesquite, screwbean mesquite), that relationship was reversed by the September 2008 monitoring period (Figure 19). From September 2008 results, it is generally evident that polymer augmentation was important in sustaining higher rates of survival across all species into the later parts of the 2008 growing season, as compared with species' response over time without polymer augmentation. The authors remain confident that this relationship will be statistically demonstrated with greater impact and clarity upon analysis of 2009 monitoring data.

The zeolite column demonstration (not statistically analyzed; Figure 21), with further study, also holds promise for high potential and economic feasibility for improving plant survival in xeric/thermic/saline conditions where groundwater remains relatively shallow (< 2 m). Greatest potential for landscape-scale application of zeolite technology is for establishing strategically located, sub-irrigated “islands” to establish and expand presence and vigor of “nurse” plants for a) natural (unassisted) seed dispersal and seedling recruitment across a larger area; and b) provision of a source for seed and/or cutting materials for artificial increase of native species .

General

Initial (2008) survival and establishment across all treatments were considered good in light of the extremely harsh climatic and soil salinity environment. Within this environmental context, soil moisture availability for plant uptake and soil salinity/sodicity are considered the chief constraints for native plant germination, emergence, establishment and vigor. These parameters are chiefly characterized by fine soil textures within the germination and early root development zone (rhizosphere; silty-clay to clay-textured surface horizons [top 25 inches; 64 cm]), and high to extreme salinity levels (15.5 – 53.1 dS m⁻¹), respectively.

In general, survival of all species declined over time, but relative magnitude of treatment differences within and across species actually increased over time, especially in relation to polymer augmentation. As noted above, limited precipitation amounts and seasonal patterns (Figure 17) appear to support soil moisture as a limiting factor prompting or facilitating this decline, particularly for non-irrigated applications. While precipitation amounts and seasonal distribution were limiting, adaptation of some of the tested species to target soil characteristics may have been limiting (e.g., alkali goldenbush).

The Indio clay, silty clay, and silt loam soil complex, with relatively high clay content (**18-27%**) and limited water holding capacity (**0.12-0.14 cm cm⁻¹**) may have reduced survival over time by means of restricting water availability to plant roots, particularly if water availability related to silt and clay components and overall aggregate structure of the 0-25 cm topsoil horizon had been adversely impacted by long-term, historic irrigation, or more likely, the cessation thereof. On sites with a dense “plow-pan” (long-duration tillage layer) of compressed clays below the soil surface, deep chiseling or ripping may be necessary to improve tilth and plant root penetration capability. If these latter measures are required, follow-up disk tillage and/or cultipacking may be necessary to reduce clods brought to the soil surface by the chisel or ripping operation.

Although weed competition from the dominant two weed species (5-hook bassia, *Bassia hyssoipifolia*; and quailbush, *Atriplex lentiformis*) produced no observable effect on seeded or transplant species establishment across the primary treatments in 2008, total (cumulative) competition from these weed species may have reduced transplant survival and seeded stand establishment over time. As the demonstration studies are now entering their second growing season following seeding/planting, timely and effective weed management will be critical to a) increase native species establishment, survival and vigor; and b) reduce or eliminate weed pressure as a confounding factor in analysis of further data sets. However, if evaluation of the native species in the face of typical weed pressure (i.e., species composition, density, cover, growth rate, and spread potential) is desired, then weed management activities may be curtailed or eliminated (but within the context of demonstration study objectives).

Differential establishment between life history and growth form groups was not related to weed competition. Influence of environmental factors such as soil features within the study (e.g., texture, salinity, organic matter, etc.) was minimized because of design replication and randomization, and ANOVA analysis that isolated replication from treatment effects. Annual and seasonal precipitation and temperature factors (Figures 3 and 17; Table 2) likewise did not appear to promote differential establishment between species, as precipitation after planting was uniformly limited across the demonstration study sites. Soil moisture reserves were severely limiting, but distribution pattern of precipitation was not unduly variable, and seasonal mean monthly temperatures were near long-term means during the study period.

The disparity between growth forms, germination characteristics, and life histories reflected in these results can be largely interpreted as characteristic of the intrinsic biology of these species in terms of adaptation to (or tolerance of) soil salinity and soil moisture, inherent seedling/sapling vigor, palatability in relation to wildlife herbivory at young (sapling) growth stages, and intrinsic rates of growth. Deeper planting of containerized transplant materials would likely have increased survival across all species and treatments by placing existing root balls within soil horizons that were intrinsically lower in salinity/sodicity, and higher in concurrent soil moisture holding capacity AND availability for plant uptake. Because of their perennial nature and associated carbohydrate allocation patterns, intrinsic growth rates are typically slow for both root and shoot. For dicotyledonous species in general, perennials typically develop root systems slowly via predominantly vertically-oriented taproots with proportionally reduced (fibrous) surface area. Reduced ability of perennial seedlings to capture limited or sporadic soil moisture thereby contributes to slower establishment rates.

From a seeding standpoint, perennial species often harbor one or more restrictive seed dormancy mechanisms requiring minimal amounts and properly timed patterns or frequencies of light,

temperature, moisture or aging (i.e., physiological dormancy), and/or physical scarification or deterioration (i.e., seed coat dormancy) (Shahba et al. 2008; Baskin and Baskin 2001; Young and Young 1992, 1986; Emery 1988). The unique combination of these factors may not have been fully met by extant environmental conditions in order to permit rapid germination (i.e., in 2008).

Reducing the time for establishment of desired levels of cover, diversity, production and habitat values is important (Lair and Wynn 2002, Allen 1995, Whisenant 1995, Anderson and Ohmart 1979). A prime objective should be to shorten or circumvent an extended ruderal and/or bare period, minimizing potential for capillary rise and salt accumulation at the soil surface following saltcedar reduction. Some sites may need consideration for higher initial establishment of rapid-cycling annual species, or perennials with rapid germination and higher intrinsic growth rates in order to cope with and adapt to harsh environmental conditions until the site stabilizes (from the standpoints of organic matter recovery, energy flow and nutrient cycling). Other sites may facilitate later seral, predominantly perennial species and accelerated successional strategies (this latter approach was followed in the demonstration studies).

Soil surface disturbance in the types and intensities needed for adequate soil surface manipulation (seedbed preparation) is absent following most saltcedar burn scenarios. Review of pertinent revegetation literature, and communication with researchers and land managers experienced in restoration of arid sites with dense, mature infestations of exotic species or other undesirable remnant cover indicate that revegetation is difficult in the absence of soil surface manipulation (i.e. some form of seedbed preparation) (Lair and Wynn 2002, Pinkney 1992, Szaro 1989, Horton et al. 1960). Different methods of achieving desirable growth medium conditions through varied techniques of seedbed preparation to enhance micro-environmental conditions in the root zone of planted species should be strongly considered and evaluated to improve moisture capture and retention, contact of seed with mineral soil, salinity reduction in surface soil layers, and mycorrhizal fungi inoculation potential (if needed).

The results of similar studies (Ritter and Lair 2007; Lair 2007) indicate that soil rhizosphere augmentation using phosphate fertilizer (often recommended for dicotyledonous planted or seeded materials) does not appear to provide sufficient immediate or long-term benefits to justify their use for native species establishment. Super-treble phosphate (PO_4) fertilizer did provide some initial (2004) establishment benefit for cool-season species, but increases in plant density response (although statistically significant) generally were insufficiently above controls to justify cost of application (approximately $\$10 \text{ ac}^{-1}$ [$\$25 \text{ ha}^{-1}$] at 2003 prices for product alone at the tested rate). In the absence of more thorough knowledge of the complex of all soil nutrient requirements, the utility and interactions of phosphorous addition cannot be postulated. Evaluation of nitrogen fertilization was not conducted because the predominance of native species planned for use in Cibola NWR restoration efforts are dicotyledonous plants, exhibiting limited response to nitrogen augmentation. Nitrogen addition on disturbed soils may also severely exacerbate ruderal (annual) weed pressure (Wilson and Ingersoll 2004, Brooks 2003, Gelt 1993).

Finally, the apparent equilibration among treatments may also have been artificially induced because of reduced sample sizes resulting from using survival as the lone measurement variable in 2008 (i.e., one sample datum per plot). As a result, emphasis was shifted under this scenario to increasing the number of replications in order to counteract this anomaly, which was not possible because of time and space constraints at the demonstration study site. As a result,

higher variability and error terms were incurred that tended to reduce findings of significant differences that may have otherwise remained at higher sample sizes. As previously mentioned, additional variables for both transplanted and seeded species will be conducted in 2009, thereby increasing greatly the number of variables, and thus corresponding sample sizes [i.e., measured value(s) per plant vs. value(s) per plot]. This will also allow for estimates of within-plot variability, which will reduce variability among treatment effects through the same ANOVA procedure.

Summary and Conclusions

The objectives of this study were to demonstrate native species selection, planting method technologies, and seed/soil/rhizosphere amendment alternatives that may hold promise for restoration of native plant communities on burned areas of the Cibola National Wildlife Refuge. Climate and soil constraints combine to produce a harsh environment for native plant establishment. This study incorporated innovative and non-traditional strategies, techniques and amendment materials that have not been previously documented in restoration of burned saltcedar infestation sites along the Lower Colorado River to dryland native plant communities and desirable wildlife habitat.

Results from this study supply the following summary findings and recommendations, based on initial growing season data (2008) only:

- In general, full irrigation through the growing season benefited most species that were tested. Prime exceptions to this finding, however, were fourwing saltbush and screwbean mesquite, which responded equally or better in terms of survival to no irrigation. These species often comprise key, dominant components of revegetation efforts on many Lower Colorado River desert riparian sites. While there were some confounding factors (e.g., adjacent drainage and/or sub-irrigation within the non-irrigated portions of the study), justification of irrigation where these two species comprise the key or dominant (i.e., majority) components of a seeded or transplanted mixture of species may not be warranted. However, if other species such as catclaw acacia, honey mesquite, and Anderson wolfberry (or other species of similar ecogeographic niches that would additionally comprise a full species palette for revegetation) are also key or dominant components of a mixture, use of irrigation is warranted based on initial results from this study.
- The use of cross-linked polyacrylamide polymer augmentation for transplant materials appears to be highly warranted by the initial results of this study. The product is economical to acquire and apply through an array of delivery mechanisms; is available commercially from numerous sources; and provides long-term, sustained moisture capture, retention and release properties when applied with proper techniques and at proper rates. The continued use of such polymer for Cibola NWR seedlings or plantings is highly recommended, for landscape-scale applications as well as further research.
- The disparity between growth form and life history groups reflected in these results can be largely interpreted as characteristic of the intrinsic biology of these species in terms of adaptation to (or tolerance of) soil salinity/sodicity, seed dormancy mechanisms, inherent seedling/sapling vigor, susceptibility to wildlife herbivory, and intrinsic rates of growth.

Future Activities and Research Needs

- Re-application and evaluation of seeding and transplanting techniques are needed that place seed or containerized root balls within deeper soil horizons that exhibit 1) soil textures more conducive for moisture release to plant roots (i.e., clay loams, sandy clay loams, sandy loams, etc.); and 2) reduced salinity levels ($<12 \text{ dS m}^{-1}$) typical of lower horizons lying below the upper, high-evaporative-demand surface layer. These techniques would include, as examples, “deep furrow” drilled seeding (seed placement in the bottom of furrows created by leading furrow openers on the drill, or alternatively by previous furrow tillage implement), which was omitted from Study 1 because of soil wetness at the time of seeding; and placement of containerized root balls within deeper soil horizons (30-60 cm) for transplanted materials, a techniques that has shown success in other riparian situations. The concept of deep-furrow seeding holds promise across multiple species for enhanced moisture capture, amelioration of environmental extremes at the soil surface, and native species establishment (Lair and Wynn 2002, Winkle et al. 1995, Merkel and Currier 1971) *if* clods can be minimized in the furrow bottoms.
- Expansion of trials involving use of polyacrylamide polymer and zeolite columns, in order to more adequately test hypotheses regarding their utility for increasing plant survival and vigor. Use of polymer in coordination with deeper seeding or planting zones, as described in A) above, would be of particular interest and innovative merit.
- Techniques and strategies need to be developed to address the issue of high salt loading in surface soil horizons resulting from salt-laden ash following burning of saltcedar. For the Cibola NWR burn site (“island unit”) in general, ash salt content (sampled and analyzed separately from underlying mineral soil and unburned, surficial, organic “duff” layers) ranged in electrical conductivity (EC_e) from 78.3 to 237.0 dS m^{-1} , with a mean EC_e value of 165.7 dS m^{-1} (BOR unpublished data). At these extreme EC_e values, techniques must be devised and tested that dissipate, re-distribute, or otherwise significantly reduce the ash loading to soil horizons within the seedbed preparation or transplant rhizosphere zone.
- Further investigation is needed regarding more efficient and effective means of pre-conditioning larger lots of seed, particularly in terms of mechanical, acid, or hot water scarification of seed exhibiting hard seed coats and corresponding seed coat-imposed dormancy (e.g., *Prosopis* spp., *Acacia* spp.). Development or acquisition of in-house equipment, or contractual arrangements with seed treatment vendors for these services is recommended.
- Further evaluation is needed to plan, design, and implement cost-effective irrigation systems with practical water sources in order to efficiently provide irrigation to sites and/or species mixture combinations that warrant irrigation for increased establishment, survival, and vigor.
- Different seeding methods were evaluated in the demonstrations at all three study sites (1, 2A, and 2B). Seeding (as opposed to transplanting containerized materials) still offers

considerable potential for cost savings over large, landscape-scale treatment areas, subject to refining seedbed preparation and seed pre-conditioning and augmentation treatments sufficient to assure successful seed germination and establishment. These methods included use of commercial standard rangeland (grass) drills; rangeland imprinters (with potential for attached seeding mechanisms); and hand-broadcasting in emulation of aerial seeding or mechanical “broadcast”-type grass drills (e.g., Trillion™) or mechanized or manual rotary broadcast seeders. Rangeland imprinters are designed to create a pattern of micro-catchments on the soil surface to enhance capture and retention of precipitation, and also to improve soil-to-seed contact via firming of the seedbed surface immediately surrounding the seed (Dixon and Carr 1999, St. John 1995, Dixon 1990).

Commercial grass drills exhibit higher degrees of consistent success in establishing native vegetation than do methods involving traditional broadcast technology, particularly on unprepared seedbeds. In concert with “deep-furrow” techniques, use of drill technology optimizes seed depth placement, soil cover and seed-to-soil contact; minimizes intra-specific, inter-row competition for seeded species; and facilitates specialized (i.e., banded or directed spray) herbicide application for weed suppression between seeded rows. Further evaluation of these methods to determine best adaptation to varying seedbed situations is still needed.

- As stated above, introducing seedbed physical relief measures as part of seedbed preparation or seeding (e.g., “deep-furrow” seeding, imprinting, and other mechanical forms of creating depressional microsites exhibiting lowered salinity for seed germination) is an innovative practice that needs further testing and expansion of use, where feasible. Additionally and perhaps synergistically, use of salt remediation products on sites with such high EC_e and SAR values may also prove valuable in increasing plant establishment and survival. For example, HydraHume (Helena Chemical Company) is a granular broadcast product available commercially that, upon activation by moisture, sequesters sodium (Na^+) by extracting and combining this element with a humic acid-based colloid. This action renders Na^+ unavailable for plant root uptake, thereby minimizing adverse impacts from root contact with the sodic soil:water matrix.
- Tapping technology from the turfgrass seed and horticultural sectors (OSU 2005, William 2004, Lee 1973), use of activated charcoal to ameliorate effects of herbicides in restoration of native species on disturbed lands is another successful technique that should be tested for feasibility where drilled seedings can be applied. Banding charcoal over the drilled seed row before broadcasting herbicides is a weed management approach successfully practiced in turfgrass seed industries (Lee 1973), and with establishment of native grass, forb, and shrub species characteristic of salt desert, alkali sink, and alkali scrub plant communities in the Lower San Joaquin Valley of California (Ritter and Lair 2007; Lair et al. 2006). This technique has definite possibilities for extension to drilled applications of native species on the Cibola NWR. Use of pre-emerge herbicides (longer residual soil activity) in conjunction with native seed/seedling safeners (charcoal) provides a strategy to minimize weed competition and maximize moisture conservation and establishment windows.

Literature Cited

- Allen, E.B. 1995. Restoration ecology: limits and possibilities in arid and semiarid lands, pp. 7-15. In: Roundy, B.A., E.D. McArthur, J.S. Haley, and D.K. Mann (eds). Proceedings: Wildland shrub and arid land restoration symposium. October 19-21, Las Vegas, NV. Gen. Tech. Rep. INT-GTR-315. U.S. For. Serv. Intermount. Res. Sta., Ogden, UT.
- Anderson, B.W. 1995. Salt cedar, revegetation and riparian ecosystems in the Southwest. Proc., Calif. Exotic Plant Pest Council 1995 Symp.
<http://www.caleppc.org/symposia/95symposium/anderson.html>.
- Anderson, B.W., and R.D. Ohmart. 1979. Riparian revegetation: an approach to mitigating for a disappearing habitat in the Southwest, pp. 481-487. In: The mitigation symposium: a national workshop on mitigating losses of fish and wildlife habitats. USDA For. Serv., Rocky Mount. For and Range Exp. Sta. Gen. Tech. Rep. RM-65. Fort Collins, CO.
- Baskin, C. C., and J. M. Baskin. 2001. Seeds – ecology, biogeography, and evolution of dormancy and germination. Academic Press, San Diego, CA. 666pp.
- Bonham, C.D. 1992. Vegetation-environmental systems analysis. Colorado St. Univ. Rangeland Ecosystem Sci. Dep. 87pp.
- Brooks M. L. 2003. Effects of increased soil nitrogen on the dominance of alien annual plants in the Mojave Desert. J. Appl. Ecol. 40: 344-353.
- Bureau of Reclamation. 2000. Consumptive use literature review of phreatophytes common to the Canadian River in Texas. Bur. Recl., Water Supply, Use and Conserv. Group, Tech. Serv. Cent., Denver, CO. 40pp.
- Busch, D.E. 1995. Effects of fire on southwestern riparian plant community structure. The Southwest. Nat. 40:259-267.
- California Exotic Plant Pest Council. 1998. Proceedings of the *Arundo* and saltcedar workshop, June 17, 1998. Ontario, CA. 158pp.
- Carpenter, A.T. 1998. Element stewardship abstract: saltcedar. The Nature Conservancy, Wildland Weeds Manage. and Res., Univ. Calif., Davis.
<http://tncweeds.ucdavis.edu/esadocs/documnts/tamaram.html>.
- Crawford, C.S., A.C. Cully, R. Leutheuser, M.S. Sifuentes, L.H. White, and J.P. Wilber. 1993. Middle Rio Grande Ecosystem: Bosque biological management plan. Middle Rio Grande Biol. Interag. Team, U.S. Fish and Wildl. Serv., Albuquerque, NM. 291pp.
- DeLoach, C.J., R.I. Carruthers, J.E. Lovich, T.L. Dudley, and S.D. Smith. 2000. Ecological interpretations in the biological control of saltcedar (*Tamarix* spp.) in the United States: toward a new understanding, pp. 819-873. In: Spencer, N.R. (ed). Proceedings of the X

International Symposium On Biological Control of Weeds. July 4-14, 1999. Montana State University, Bozeman, MT.

DiTomaso, J.D. 1996. Identification, biology and ecology of saltcedar, pp. 4-8. In: University of California Cooperative Extension. 1996. Proceedings of the Saltcedar Management Workshop, June 12, 1996. Rancho Mirage, CA.

Dixon R. M. 1990. Land imprinting for dryland revegetation and restoration, pp. 14-22. In: Berger J. J. (ed). Environmental Restoration: Science and Strategies for Restoring the Earth. Island Press, Covelo, CA.

Dixon R. M., and A. B. Carr. 1999. Land imprinting for restoring vegetation in the desert Southwest, pp 103-109. In: Cannizzaro P. J. (ed). Proc., 25th Annual Conference on Ecosystems Restoration and Creation. Hillsborough Community College and Institute of Florida Studies, Tampa, Florida.

Dixon, W.J. (ed). 1992. BMDP release 7 statistical software manual. Univ. California Press, Berkeley, CA. 1500pp.

Dudley, T.L., C.J. DeLoach, J.E. Lovich, and R.I. Carruthers. 2000. Saltcedar invasion of western riparian areas: impacts and new prospects for control, pp. 345-381. In: McCabe, R.E., and S.E. Loos (eds). Transactions of the Sixty-Fifth North American Wildlife and Natural Resource Conference. March 24-28, 2000. Rosemont, IL.

Eberts, D. 2000. Biocontrol of saltcedar: background and considerations for possible use on the Canadian River, Texas. Tech. Memo. No. 8220-01-01. Bur. Recl., Tech. Serv. Cent., Denver, CO. 8pp.

Emery, D. E. 1988. Seed propagation of native California plants. Santa Barbara Botanic Garden, Santa Barbara, CA. 115pp.

Friedman, J., and Y. Waisel. 1966. The influence of wind velocity and fuel density on the burning of the litter of *Pinus halepensis* and *Tamarix aphylla*. La-Yaaran 16:93-94.

Gelt J. 1993. Abandoned farmland often is troubled land in need of restoration. Arroyo 7(2): 1-10.

Gomez, K.A., and A.A. Gomez. 1984. Statistical procedures for agricultural research. John Wiley and Sons, New York, NY. 679pp.

Horton, J.S., F.C. Mounts, and J.M. Kraft. 1960. Seed germination and seedling establishment of phreatophyte species. USDA For. Serv., Rocky Mount. For. and Range Exp. Sta. Paper No. 48. Fort Collins, CO.

Lair, K.D. 2007. Study summary – Atwell Island planting method and soil amendment revegetation trial. Tech. Memo. No. 86-68220-07-09. Bur. Recl., Tech. Serv. Cent., Denver, CO. 29pp.

- Lair, K.D., and D. Eberts. 2002. Preliminary assessment of site potential for establishment and propagation of the saltcedar leaf beetle (*Diorhabda elongata*) along the Canadian River within Lake Meredith National Recreation Area, Texas. Tech. Memo. No. 8220-02-03. Bur. Recl., Tech. Serv. Cent., Denver, CO. 29pp.
- Lair, K.D., N. Ritter, and A. Howard. 2006. Use of activated charcoal to protect native seeds from herbicides (California). Restoration Note No. 109. Ecol. Restor. 24(2):122-124.
- Lair, K.D., and S. L. Wynn. 2002. Revegetation strategies and technology development for restoration of xeric *Tamarix* infestation sites. Tech. Memo. No. 8220-02-04. Bur. Recl., Tech. Serv. Cent., Denver, CO. 48pp.
- Lee, W.O. 1973. Clean grass seed crops established with activated charcoal bands and herbicides. *Weed Science* 21(6):537-541.
- Lovich, J.E. 1996. A brief overview of the impact of tamarisk infestation on native plants and animals, pp. 13-15. In: University of California Cooperative Extension. Proceedings of the Saltcedar Management Workshop, June 12, 1996. Rancho Mirage, CA.
- Manly, B.F.J. 1994. Multivariate statistical methods, a primer. Chapman and Hall, New York, NY. 215pp.
- McDaniel, K.C., K.W. Duncan, and J.P. Taylor. 2000. Saltcedar (*Tamarix* spp.) control in New Mexico, pp. 173-184. In: Center for Grazinglands and Ranch Management. Proc., Rangeland Weed and Brush Management: the Next Millennium Symposium. Oct. 19-21, 2000. San Angelo, TX.
- Merkel, D.L., and W.F. Currier. 1971. Critical area stabilization in New Mexico. USDA Agric. Res. Serv. Rep. No. 7. Las Cruces, NM.
- Parametrix, Inc. 2006. Cibola fire: burned area rehabilitation plan review and approval. Prepared for U.S. Fish and Wildlife Service, Southwest Region 2, by Parametrix Inc., Albuquerque, NM. 26pp + appendices.
- Pinkney, F.C. 1992. Revegetation and enhancement of riparian communities along the lower Colorado River. USDI Bureau of Reclamation, Ecological Resources Division, Denver, CO. 187pp.
- Polat, E., Karaca, M., Demir, H., and Onus, A.N. (2004). Use of natural zeolite (clinoptilolite) in agriculture. *Journal of Fruit and Ornamental Plant Research*, 12 (Special Edition): 183-189.
- Ritter, N.P., and K.D. Lair. 2007. Central Valley Project Improvement Act Land Retirement Demonstration Project: a synthesis of restoration research conducted near Tranquillity, California. USDI Interagency Land Retirement Team, Fresno, CA. 70pp.
- Scurlock, D. 1995. Environmental history, pp. 12-28. In: Finch, D.M., and J.A. Tainter. Ecology, diversity, and sustainability of the Middle Rio Grande Basin. USDA For. Serv., Rocky Mount. For and Range Exp. Sta. Gen. Tech. Rep. RM-GTR-268. Fort Collins, CO.

- Shahba, M.A., Y.L. Qian, and K.D. Lair. 2008. Improving seed germination of saltgrass under saline conditions. *Crop Sci.* 48:756-762.
- St. John, T. 1995. Specially-modified land imprinter inoculates soil with mycorrhizal fungi. *Restor. Manage. Notes* 14(1):84-85.
- Steel, R.G.D., and J.H. Torrie. 1980. Principles and procedures of statistics - a biometric approach. McGraw-Hill Publ. Co., New York, NY. 633pp.
- Szaro, R.C. 1989. Riparian forest and scrubland community types of Arizona and New Mexico. *Desert Plants* 9:69-139.
- The Ohio State University (OSU). 2005. Controlling weeds in nursery and landscape plantings – controlling plant damage from herbicide residues. Bull. 867, The Ohio St. Univ. http://www.ohioline.osu.edu/b867/b867_10.html.
- University of California Cooperative Extension. 1996. Proceedings of the Saltcedar Management Workshop, June 12, 1996. Rancho Mirage, CA. 61pp.
- USDA Natural Resources Conservation Service (NRCS). 1980. Yuma – Wellton Area Soil Survey. USDA Nat. Resources Conserv. Serv., Yuma, AZ.
- Warren, D.K., and R.M. Turner. 1975. Saltcedar (*Tamarix chinensis*) seed production, seedling establishment, and response to inundation. *Ariz. Acad. Sci.* 10:135-144.
- Whisenant, S.G. 1995. Landscape dynamics and arid land restoration, pp. 26-34. In: Roundy, B.A., E.D. McArthur, J.S. Haley, and D.K. Mann (eds). Proceedings: Wildland shrub and arid land restoration symposium. October 19-21, Las Vegas, NV. Gen. Tech. Rep. INT-GTR-315. U.S. For. Serv. Intermount. Res. Sta., Ogden, UT.
- Wiesenborn, W.D. 1996. Saltcedar impacts on salinity, water, fire frequency, and flooding, pp. 9-12. In: University of California Cooperative Extension. Proceedings of the Saltcedar Management Workshop, June 12, 1996. Rancho Mirage, CA.
- William, R.D. 2004. Testing for and deactivating herbicide residues. PNW Weed Manage. Handbook 2004. http://weeds.ippc.orst.edu/pnw/weeds?05W_HNAM14.dat.
- Wilson M., V., and C. Ingersoll, A. 2004. Why pest plant control and native plant establishment failed: a restoration autopsy. *Natural Areas J.* 24(1):23-31.
- Winkle, V.K., W.K. Ostler, W.D. Gabbert, and G.E. Lyon. 1995. Effects of seedbed preparation, irrigation and water harvesting on seedling emergence at the Nevada Test Site, pp. 135-141. In: Roundy, B.A., E.D. McArthur, J.S. Haley, and D.K. Mann (eds). Proceedings: Wildland shrub and arid land restoration symposium. October 19-21, Las Vegas, NV. Gen. Tech. Rep. INT-GTR-315. U.S. For. Serv. Intermount. Res. Sta., Ogden, UT.

- Young, J. A., and C. G. Young. 1992. Seeds of woody plants in North America. Dioscorides Press, Portland, OR. 407pp.
- Young, J. A., and C. G. Young. 1986. Seeds of wildland plants. Timber Press, Portland, OR. 236pp.
- Zavaleta, E. 2000a. The economic value of controlling an invasive shrub. *Ambio* 29(8):462-467.
- Zavaleta, E. 2000b. Valuing ecosystem services lost to Tamarix invasion in the United States, pp. 261-300. In: Mooney, H.A., and R.J. Hobbs. *Invasive species in a changing world*. Island Press, Washington, DC.
- Western Regional Climate Center (WRCC). 2005. Monthly climate summary: Yuma Proving Ground, Arizona (029654) (<http://www.wrcc.dri.edu/cgi-bin/cliRECTM.pl?azyupg>) and Blythe, California (040924) (<http://www.wrcc.dri.edu/cgi-bin/cliRECTM.pl?cablyt>).

Additional Comments:

Scott O'Meara

Bureau of Reclamation

Environmental Applications and Ecological Research Group

Technical Service Center

P.O. Box 25007, Mail Code 86-68220

Denver, CO 80225-0007

303-445-2216 office

303-445-6328 fax

someara@do.usbr.gov